

MASSACHUSETTS INSTITUTE OF TECHNOLOGY
HAYSTACK OBSERVATORY
WESTFORD, MASSACHUSETTS 01886
 January 4, 2006

Telephone: 781-981-5407
Fax: 781-981-0590

To: RFI Group
 From: Alan E.E. Rogers
 Subject: Estimate of systematic errors in search for EOR global step

In memos 15 and 16 I described how a small antenna structure might respond gradually with frequency so that the global step could be detected in the residuals to a polynomial fit to the total power data. Figure 1 is a diagram which shows the concept of the system. Figure 2 shows the residuals to a polynomial fit to the receiver output which includes an EZNEC modeling of the “fat” dipole. In order to maintain sufficient numerical accuracy in the polynomial the fitting function used was

$$z(f) = \left\langle s(f) - \sum_0^{N-1} a_k b^k \right\rangle$$

where $b = 1024(f - f_{start}) / (f_{stop} - f_{start})$ in place of expression in memo 16. In addition the actual polynomial fitting function takes the $\log(\)$ of the function and restores the function with the $\text{pow}(\)$ to further relieve the stress on numerical accuracy.

The simulation in figure 2 assumes the antenna out put is

$$\left(1000(f/100)^{-2.2} + 3 + eor \right) (1 - \Gamma^2)$$

where Γ is the antenna reflection coefficient from EZNEC.

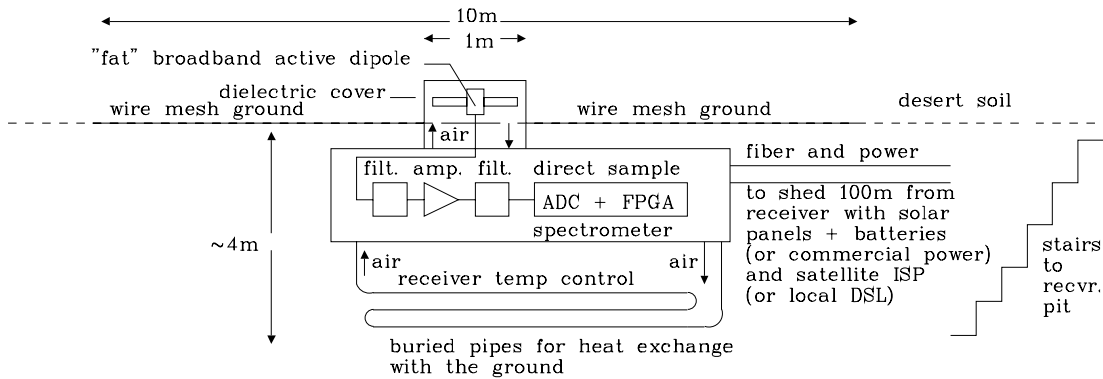

- Notes: 1] 0.6m x 0.1m dipole 0.2m over ground
or dipole in recessed cavity
- 2] Antenna is on ground to avoid ground reflections
and minimize antenna response at horizon
- 3] All structures from which reflections could originate
are either very close or very distant and small in
angular size in order to avoid any instrumental
response which changes rapidly with frequency.

EOR "step"
recvr.
aeer 23dec05

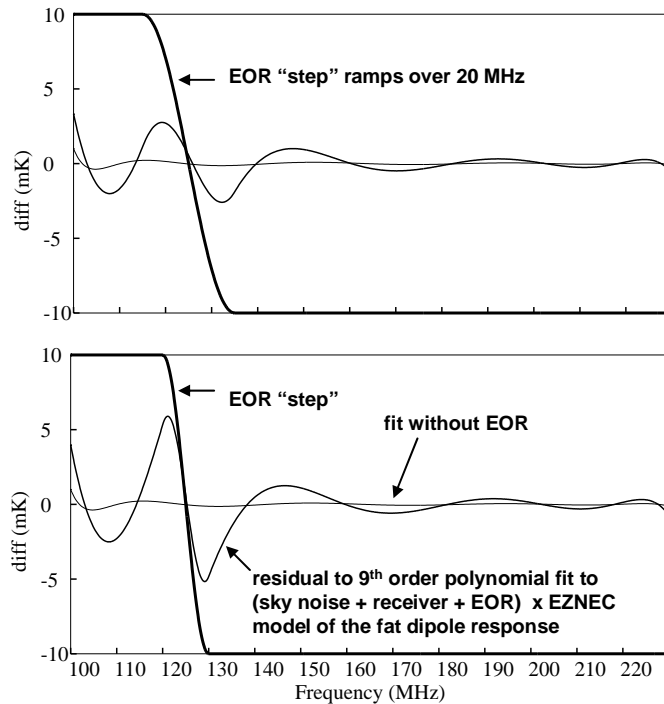

The fractional signals due to scattered external noise is $\sigma^2 Gh/16$ and that from receiver noise, which is assumed to be correlated with the receiver output is $\sigma^{1/2} \lambda \theta Gh / (16\pi r)$

Where

σ = reflectivity ~ 0.1

Gh = relative antenna gain in direction of scatter ~0.01 for horizon

λ = wavelength ~ 3m

θ = angle subtended by scatter

r = distance to scatterer.

Using these relations along with an assumed path loss of 200 dB for the forward scatter from meteor trails I obtained the following estimated of error sources.

Source	Object	Effect
Galactic noise	Tree $10^\circ \times 10^\circ$	2 ppm
“	Mountain $10^\circ \times 20^\circ$	2 ppm
Receiver noise	Tree at 100 m	4 ppm
Receiver noise	Mountain at 2 km	3 ppm
FM 100 kw	Moon-path loss ~240 dB	10 mK in 1 MHz
FM 100 kw	Aircraft – path loss ~210 dB 10/200 km 1m^2 xsect	10 K in 1 MHz
FM 100 kw	Meteors – path loss ~200 dB	100 K peak in 1 MHz 100 mK average
FM 100 kw	Sporadic E	Very strong- avoid daytime obs.
FM 100 kw	Tropospheric ducting	Very strong but only occasional
FM 100 kw	Troposcatter/conscatter ~200 dB path loss at 300 Km	100 K in 1 MHz but would be reduced by 30 dB more in mountain valley
Jupiter	~ 1 J at 100 MHz	~1 mK

Notes:

- 1] Daytime observations would be effected by the sun as well as sporadic E propagation of distant RFI.
- 2] Night-time only observations are preferred and those in March would be least contaminated by the Galaxy
- 3] The forward scattering of strong Earth based transmitters is likely to be the most serious problem.

- 4] One of the best locations I could find by looking at the Earth's topography is that of Deep Springs, California. This is a deep remote valley for which the only RFI in the 100-230 MHz would be from transmitters in the valley, satellites, Meteor scatter and sporadic E. This site is about 40 miles out of the Owens Valley on route 168 and about 20 miles past CARMA on the same road. The region close to the Deep Springs lake is flat and desert like without trees and only a few little shrubs.
- 5] Areas of the Earth for which FM is assigned below 80 MHz may be preferable as the meteor scatter is limited by the ionization height of about 120 km to a range of 2000 km. [If meteor scatter is really the main limitation then remote locations like the flat pacific Wake Island might be considered.]
- 6] Radiated receiver noise could be cancelled by using 2 identical LNAs with quadrature hybrids on input and output. However the added loss in the hybrid may degrade overall performance.
- 7] Typical "ping" rates for meteor scatter are about 1 per minute. At 150 MHz the typical "ping" durations is proportional to λ^2 and is about 100 ms so that the dilution factor is about 30 dB. However it should be possible to detect all the "pings" with a filter centered on the strongest FM transmitters and excise the data for the duration of the meteor burst.
- 8] Calibration of spectrometer would be accomplished by comparison of the sidereal variation of total power with a sky model.

References:

Cevolani et al., Planet space Science, 43, 765-772, 1995.
<http://pulsar.princeton.edu/~joe/k1JT/wsJT300.pdf>

Sullivan et al, Science, 199, 377-388, 1978.

www.deepsprings.edu

www.kolubus.fi/oh5iy/msobs/vhfdxpro.html

Sugar, Proc IEEE, S2, 116, 1964.