

**MASSACHUSETTS INSTITUTE OF TECHNOLOGY
HAYSTACK OBSERVATORY
WESTFORD, MASSACHUSETTS 01886**

February 3, 2006

Telephone: 781-981-5407
Fax: 781-981-0590

To: RFI Group
From: Alan E.E. Rogers

Subject: Active antenna for spectrum monitor and EoR

Figure 1 shows the mechanical design for a lightweight broadband antenna. The design is optimized for the measurement of the EoR spectrum in the range 100 to 200 MHz. The antenna is assembled of simple parts which can be easily transported and quickly assembled.

Figure 2 shows the circuit diagram for a low noise preamp which could be mounted directly to the antenna terminals. The design includes a low loss input switch and noise calibration for accurate calibration of the antenna temperature as described in memo #21. The 3 position switch is controlled by the voltage applied to the center conductor of the coax cable. A balun to reject the common mode is provided by winding 6 turns of a thin output coax onto a ferrite core. Following the balun the thin coax is transitioned to a low loss LMR-240 cable which then connects to the spectrometer back-end whose block diagram is shown in figure 3.

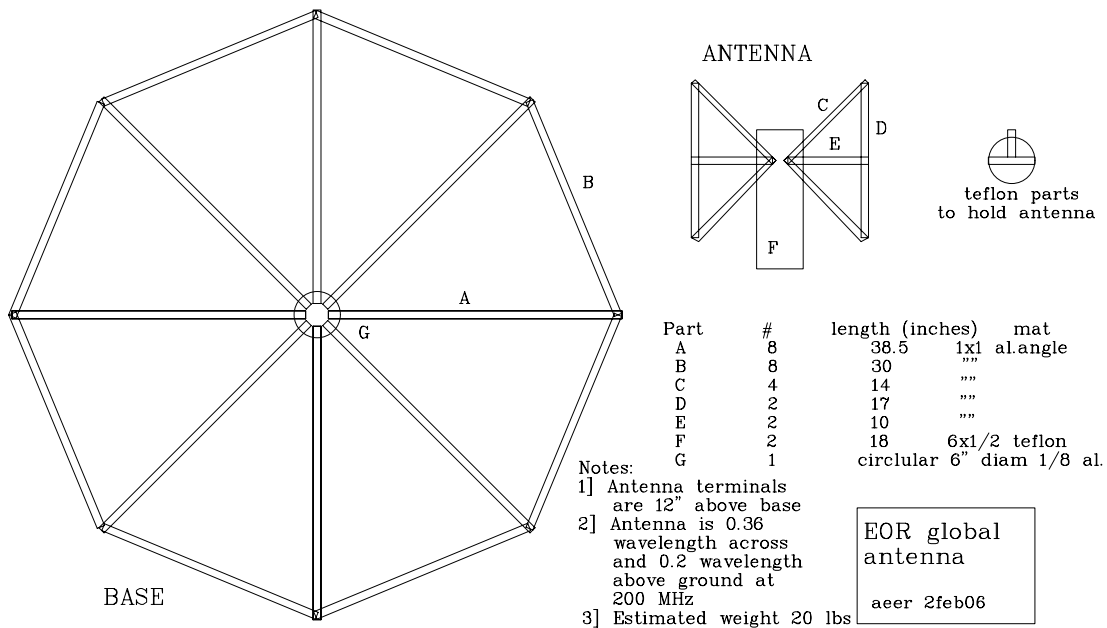

Figure 1. Broadband active antenna mechanical parts

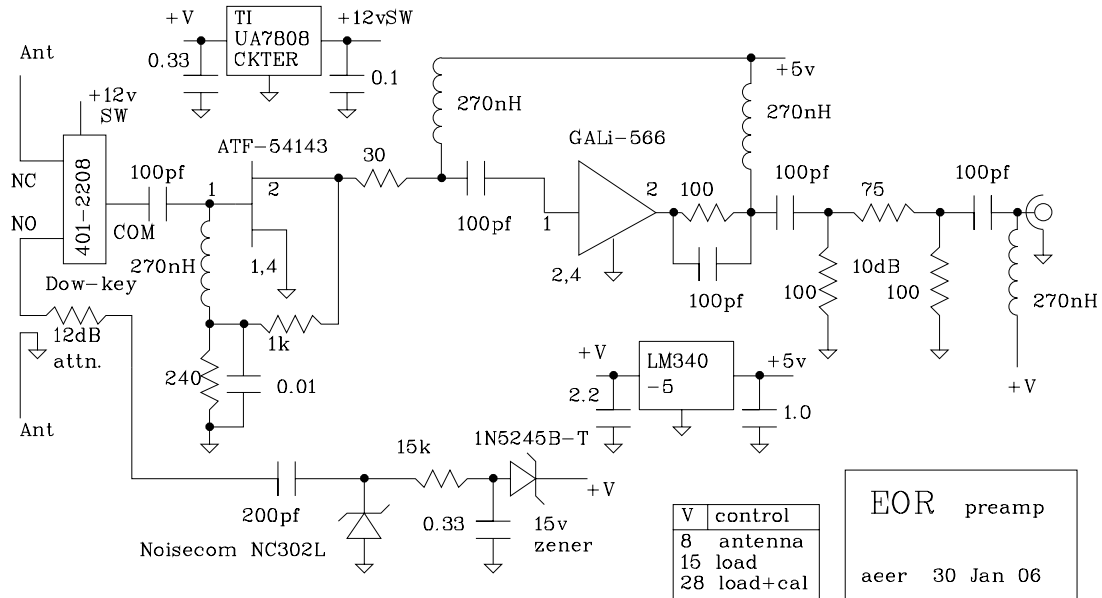

Figure 2. Circuit diagram for broadband active antenna

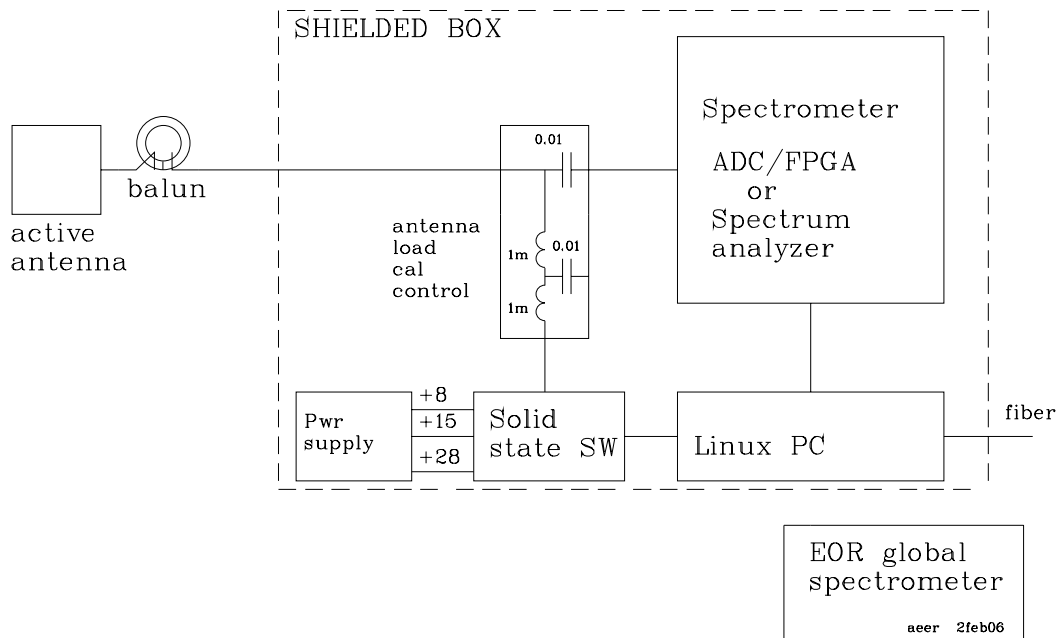

Figure 3. Block diagram