

MOSAIC USER'S GUIDE

Version 1.00
July, 2010



Photo by Alan Rogers

Mesospheric Ozone System for Atmospheric Investigations in the Classroom

Introduction

Welcome to MOSAIC, the **Mesospheric Ozone System for Atmospheric Investigations in the Classroom**. The MOSAIC User's Guide (MUG) is intended as a primer for educators who are interested in using MOSAIC as the focal point for classroom lessons and activities. Other MOSAIC users should find value here also.

MOSAIC was developed by Dr. Alan E.E. Rogers and Dr. Vincent Fish at MIT's Haystack Observatory in Westford, Massachusetts. The philosophy behind this project was to develop a low-cost scientific instrument capable of making meaningful observations of Mesospheric Ozone. Memoranda regarding MOSAIC can be found at the following URL:

http://www.haystack.mit.edu/edu/undergrad/VSRT/VSRT_Memos/memoindex.htm

The low cost is achieved by using off-the-shelf satellite TV dishes and receivers, thereby taking advantage of the economies of scale for these mass-produced components. The two biggest contributors to MOSAIC cost are the high-speed 12-bit ADC card and a high-end PC, which are required for the signal processing.

European satellite receivers operate in the 10 GHz – 12 GHz frequency band, while satellite receivers in the US operate at 12.20 – 12.75 GHz. The European components have been chosen for MOSAIC because the specific frequency of interest is a rotational transition of Ozone (O₃) at 11.0724545 GHz.

MOSAIC may be divided into three parts: The hardware, the software, and the Graphical User Interface (GUI). Students may interface to a number of active MOSAIC units through the web-based GUI which is hosted by MIT Haystack. As an educator, you may want to familiarize yourself with the hardware components. The software components run only at the local MOSAIC host site, and therefore are not visible to users of the GUI.

As you can see from the Haystack memos, MOSAIC is closely linked with another project called VSRT (Very Small Radio Telescope). The VSRT system consists of two satellite dishes and slightly different back-end electronics and software. It is less expensive than MOSAIC, and also makes an excellent tool for classroom instruction. For the technically advanced: VSRT is an interferometer, while MOSAIC is a radiometer.

Lessons for MOSAIC and the VSRT may be found on the Haystack web site under the Education and Outreach heading.

Mesospheric Ozone System for Atmospheric Investigations in the Classroom

Glossary of terms

ADC	Analog-to-Digital Conversion. The incoming electromagnetic wave is amplified and down converted (see below) as an analog voltage. This signal is transmitted down a coaxial cable to the computer. Before the computer can accept and process the signal, it must be sampled and converted into digital bits.
Antenna	The satellite dish and LNB assembly make-up the antenna.
Antenna Temperature	From the second law of thermodynamics, the antenna is assumed to be in thermal equilibrium with the object in the beam. The antenna temperature is the temperature that a resistor would have if it were to generate the same power density at frequency ν that is observed coming from the antenna.
Aperture	Aperture is the area presented to the incident electromagnetic radiation. For the offset parabolic dish used in MOSAIC, the aperture is approximated by the diameter of the reflecting surface. When you select more than one MOSAIC unit through the GUI, you are combining the apertures of the individual units, increasing signal quality.
Bandwidth	This term has several meanings. In computing, this is the throughput or transfer rate of the processor. In signal processing, this is the measure of the width of a range of frequencies, measured in hertz.
Beamwidth	The size of the spot on the sky that your antenna “sees”. Technically speaking, this is the angle in which half of the incoming power can be seen. Numerically, the beamwidth is on the order of $1.22 \lambda/D$, where λ is the wavelength of interest and D is the diameter of the dish. Remember that these angles are two-dimensional, so when you determine that MOSAIC has a beamwidth of 4° ($\lambda \sim 2.7$ cm, $D \sim 46$ cm, and use radians, not degrees!), that is a circle on the sky with a diameter of 4° .
Black Body	An ideal black body would absorb 100% of the electromagnetic spectrum incident on its surface. A black body would also radiate a spectrum dependent on its temperature (a black-body curve), per Planck’s Law.
Brightness Temperature	This is the temperature at which a black body would have to be in order to generate the observed intensity at frequency ν (using Rayleigh-Jeans approximation to Planck black body radiation formula). Note that many radio sources, such as radiation produced by the cyclotron or synchrotron process, are not actually thermal emitters. Still, radio astronomy uses the temperature conventions since black bodies and resistive loads are well-defined benchmarks. The expected peak brightness temperature of Mesospheric Ozone is on the order of tens of milliKelvins.

Mesospheric Ozone System for Atmospheric Investigations in the Classroom

Introductory physics students will probably be most confused by this “temperature” terminology. Power per unit frequency may not be much better, but at least you can point to a black body curve and tell them that the area under this curve could have these units. For the 11 GHz range, the Rayleigh Jeans approximation yields $1 \text{ mK} \sim 1.38 \times 10^{-26} \text{ W/Hz}$.

- Calibration** The act of establishing the power received by the antenna. Presently, MOSAIC must be calibrated manually by placing an absorbing material in front of the feed. Scientists at Haystack are looking to improve this with an automated method.
- Down Conversion** A frequency translation of a signal. Typically, this is a multiplication of the signal of interest with a known frequency, selected somewhat near the signals of interest. You get the sum and the difference, and keep only the lower frequency difference via filtering. There are two stages of down conversion in the MOSAIC electronics. The first stage occurs in the LNB; the second stage occurs in the spectrometer down-converter hardware.
- Feed (Horn)** The device placed at the focal point, which collects the microwave energy. In MOSAIC, this is synonymous with the LNB or LNBF. The terms feed, horn, and feedhorn are microwave engineering terms frequently used by radio scientists. Technically, the feed is a waveguide open at one end which passes the desired frequencies to the low noise amplifier. The Low Noise Block contains amplifiers and the first down-conversion stage. Since they are all contained within one physical package, it is convenient to refer to that unit as the Feed, LNB, or LNBF.
- Frequency Calibration** The LO (Local Oscillator, see below) in the LNB is not as precise as this application requires, since it was designed for satellite TV signals and not scientific spectroscopy. Harmonics of a 10 MHz signal derived from an oven-controlled crystal are injected into the signal path about every 90 seconds to allow the software to correct for inaccuracies in the LNB LO.
- GUI** Graphical User Interface. This is the window through which students and researchers may access the MOSAIC data. The GUI runs on the Haystack Observatory server. The server provides ten-minute averaging of the 75 second samples, plots as requested, text files of the raw data, and information files regarding the data.
- IF** Intermediate Frequency. This is the difference between the signal of interest and the LO, which is a by-product of mixing (see below). The IF of the LNBF is 950 – 1950 MHz, while the IF of the second stage in the spectrometer is 0 – 10 MHz.

Mesospheric Ozone System for Atmospheric Investigations in the Classroom

- Interferometer** The process of precisely summing the signals from two or more separated radio telescopes is called interferometry. The separation between the instruments is called the baseline. Radio Astronomers use VLBI (Very Long Baseline Interferometry) to synthesize large apertures. VSRT uses satellite dishes and LNBFs similar to MOSAIC to form an inexpensive interferometer for classroom use. The MOSAIC instrument is not an interferometer, it is a radiometer (see below).
- LNB, LNBF** Low-Noise Block down-converter, Low-Noise Block down-converter with Feedhorn. The electronics which pick-up the microwave signal. The input frequency sensitivity of the LNB is from 10.7 GHz to 11.7 GHz. These frequencies are too high to transmit any significant distance, so the first stage of down conversion occurs immediately in the LNB. The LO of approximately 9.75 GHz yields a more transportable frequency range of 950 MHz – 1950 MHz.
- LO** Local Oscillator – a single-frequency source which is one of the inputs to the mixer stage. The other input to the mixer is the microwave signal and the output of the mixer is the IF. The frequency of the LO is thoughtfully selected for the IF frequency range of interest.
- Local Host** This is the PC to which the MOSAIC antenna is connected. The host collects the ADC samples, executes an FFT to convert the time-domain samples into the spectral domain, and once per day performs an HTTP file transfer to the Haystack Observatory server.
- Mixing** Mixing is the electronic term for the multiplication of two signals, usually accomplished by non-linear circuitry. For signals of Freq A and Freq B, Freq (A x B) yields two components, a higher frequency (A+B) and a lower frequency (A-B). Usually, as is the case for the MOSAIC circuitry, the higher frequency component is filtered out (down conversion).
- Octave** Examples are given in the MOSAIC Memos on how students could write their own data processing programs in the Octave programming language. It is freeware which is mostly compatible with Matlab.
- Offset Parabola** The collecting surface of the satellite dish is relatively small. If the design was not offset, the LNB would block a fraction of the incident signal.
- Oven Crystal** The LO in the LNB is not precise enough for scientific use. Frequencies derived from an oven-controlled crystal at 10 MHz are injected into the feed to act as a frequency reference.

Mesospheric Ozone System for Atmospheric Investigations in the Classroom

Planck's Law	<p>Planck's Law describes the electromagnetic radiation from a black body over all wavelengths. The typical form is a function of frequency and temperature. The intensity I is a measure of power per unit area per unit solid angle per unit frequency.</p> <p>Introductory physics students are familiar with power as an absolute measurement, for example a light bulb is either 60 W or 100 W. They are less familiar with the notion that spectral radiance may be spread out over a range of frequencies, and the total power emitted by an object would be the area under the spectral curve.</p>
Primary Beam and Side Lobe	<p>(a.k.a. Main Lobe, Main Beam). Here is a definition by analogy. Think of being in a completely dark room, then turn on a flashlight and point it at the wall. The bright central spot where much of the light is found would be the primary beam, and the less-lit area surrounding that would be the side lobe. This happens due to imperfections in the flashlight – the reflector isn't perfectly parabolic, the bulb filament isn't exactly at the focal point, and the bulb isn't a point source. A parabolic radio antenna is a lot like the flashlight, only it receives rather than transmits. Some energy that comes in from off the primary axis of the parabola will still reach the focal point, where the LNBF will detect it. The beamwidth (see above) is the angular size of the main lobe as projected onto the sky.</p>
Radiometer	<p>In the simplest terms, a radiometer measures power flux.</p>
Rayleigh Jeans	<p>When plotted as relative power output versus increasing frequency, a black-body curve appears to start as a nearly monotonically increasing function (logarithmic scales), reaches a peak, then falls off with shorter wavelengths (Planck's Law). For $(h\nu)/(kT) \ll 1$, which is true for most observations in radio frequencies, the Rayleigh Jeans approximation of this may be used.</p>
Sample Rate	<p>A signal must be sampled at least twice as often as the highest frequency of interest (Nyquist Theorem). For MOSAIC, the ADC samples at a rate of 20 MHz.</p>
SNR	<p>Signal-to-Noise ratio. Also seen as S/N.</p>
Spectrometer	<p>An instrument which measures the power spectrum. A spectrometer could use an array of radiometers with individual filters to split the bandwidth into many channels or it could use digital signal processing to Fourier transform the signal and accumulate the power into different frequency bins. MOSAIC uses the latter technique.</p>

Mesospheric Ozone System for Atmospheric Investigations in the Classroom

- System Temperature** This is the total power received, which would be the sum of the source output, the noise in the receiver, the ambient noise in the atmosphere, and any stray sources (such as ground clutter) which “leak” into the beam through side lobes.
- VMR** Volume Mixing Ratio. The volume mixing ratio of a gas is defined as the ratio of the number density of the gas (the number of molecules per unit volume) to the total number density of the atmosphere. This is a dimensionless number. By convention, constituents in the lower atmosphere are specified in parts per billion by volume (ppbv), while measuring the ozone in the mesosphere is better suited to parts per million by volume (ppmv). The relationship between VMR and antenna temperature is derived in MOSAIC Memo #069.
- VSRT** Very Small Radio Telescope. VSRT is an antecedent of MOSAIC. Some of the early MOSAIC documentation on the Haystack web site can be confusing, as the authors sometimes used the expression VSRT to refer to the 18” satellite dish and LNBF, rather than the entire project. VSRT is a two-dish system, in which the signals are summed in the analog domain and digitized into a USB bit stream for insertion into a PC.

The Hardware

Offset Parabolic Dish



Frequency
Calibration

The LNB
(Feed)

An antenna set-up, attached to the side of a building.

Photo by Alan Rogers

Mesospheric Ozone System for Atmospheric Investigations in the Classroom

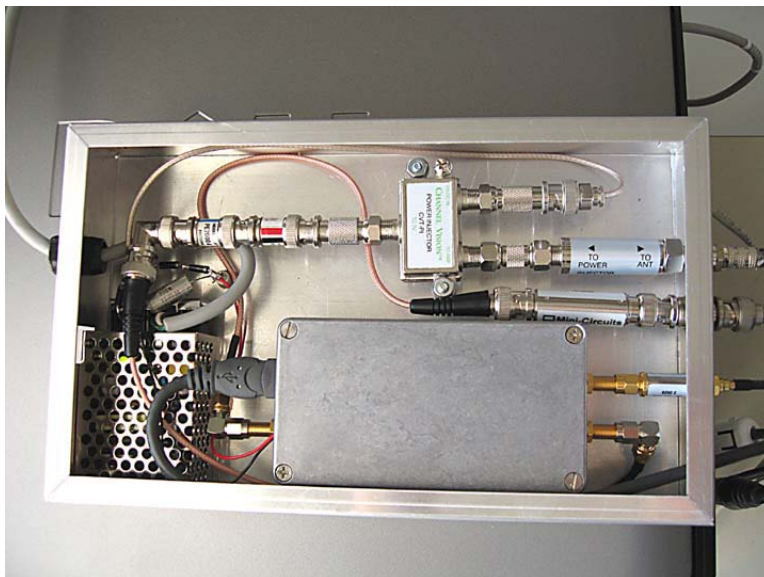

The Ozone spectrometer down-converter with oven-controlled crystal oscillator

Photo by Alan Rogers

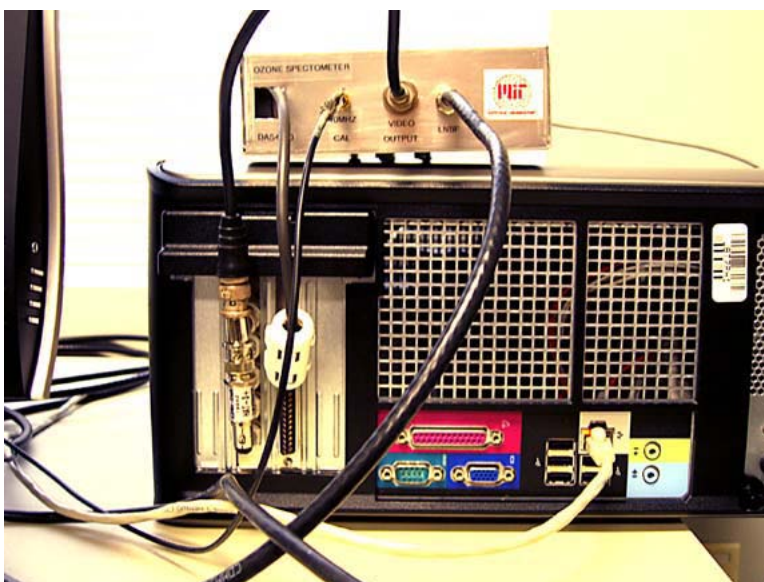

The Ozone spectrometer down-converter, ADC card and PC

Photo by Alan Rogers

Mesospheric Ozone System for Atmospheric Investigations in the Classroom

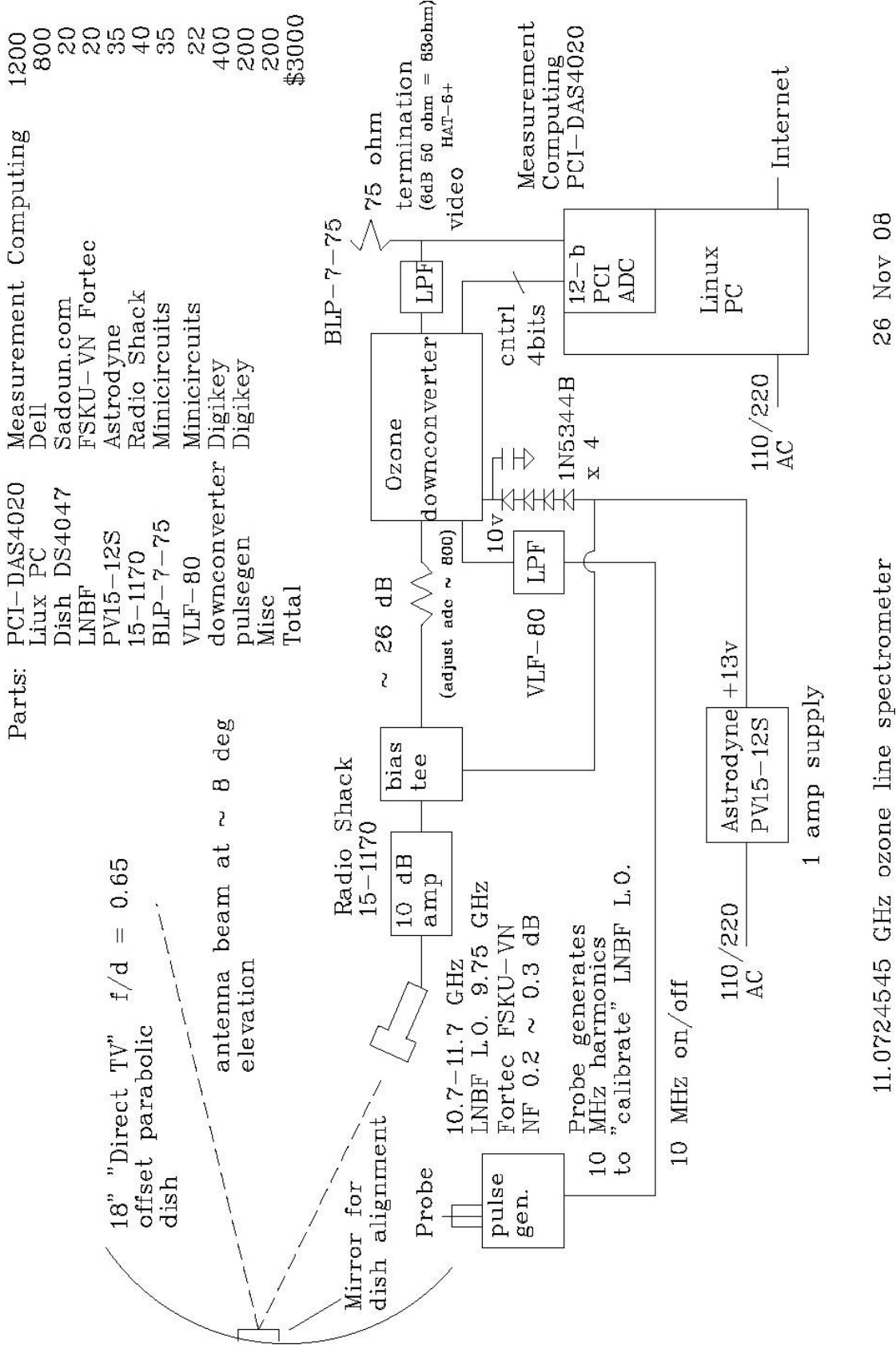

11.0724545 GHz ozone line spectrometer

26 Nov 08

Drawing by Alan Rogers

Mesospheric Ozone System for Atmospheric Investigations in the Classroom

The Graphical User Interface (GUI)

Go to www.haystack.mit.edu/ozone

You will find a default screen that should look similar to this:

The screenshot shows a web browser window titled "Plot Mosaic ozone data - Mozilla Firefox" with the URL "http://www.haystack.mit.edu/ozone/". The page content is titled "MOSAIC ozone data access" and is divided into four main steps:

- Step 1: Select data by date** (you can enter Day ddd or mm:dd i.e. 15 Feb is 46 or 02:15)
Start Year: Start Day: Stop Year: Stop Day:
- Step 2: Apply filters to data (optional)**
 Show only data
From Start Localtime: hr min To Stop Localtime: hr min Each Day
Localtime is defined so that sunrise and sunset occur at 6 and 18 hrs, respectively, every day.
 Show only data when the sun is - or check for nighttime data only
Above: deg and Below: deg Elevation
Example: Setting "below" to -10 degrees selects data for which the sun is at least 10 degrees below the horizon.
- Step 3: Select spectrometer(s)**
 Chelmsford High School, MA Haystack Observatory, MA Bridgewater State College, MA Union College, Schenectady, NY
 University of North Carolina at Greensboro, NC SP6 SP7 SP8 SP9
- Step 4: Select plot type**
 Ozone spectrum: above and below 80km fit together above and below 80km fit separately
 Ozone vs localtime: 60 30 20 10 minutes averaging time (turn off filters to get full range of localtime)
 Ozone vs date: 20 10 4 2 1 days averaging time modulo 1 year (use filter for nighttime data)
Select "modulo 1 year" to wrap data by year (e.g., all data taken on January 3, regardless of year, are averaged and plotted as day 3)

Advanced Options: (requires a detailed knowledge of the spectrometer) [see MOSAIC memos](#)

- include total power in plots vs time include data with high Tsys (probably due to rain)
- plot only total power vs time for selected time range plot cal freq. vs time for start day
- plot total power vs time for start day(high res) high resolution spectrum use Tsys correction solve for Mesopause temperature

Buttons:

Done

Mesospheric Ozone System for Atmospheric Investigations in the Classroom

Step 1: Select data by date (you can enter Day ddd or mm:dd i.e. 15 Feb is 46 or 02:15)

Start Year Start Day Stop Year Stop Day

The MOSACI GUI allows the user to select the data they wish to analyze by specific start and stop dates. The format is YEAR and DAY. Remember that 2008 was a leap year, so there were 366 days in that year.

The default begins on Day 1 of 2008 and ends on Day 366 of 2100. The first MOSAIC system was installed after Day 1 2008, so this day precedes the start of all data.

You may find an ordinal date converter at: <http://www.fs.fed.us/raws/book/julian.shtml>

For those who want the convenience of the civil (Gregorian) calendar, you may enter the date in the form of mm:dd.

Step 2: Apply filters to data (optional)

Show only data
From Start Localtime hr min To Stop Localtime hr min Each Day

Localtime is defined so that sunrise and sunset occur at 6 and 18 hrs, respectively, every day.

Show only data when the sun is - or check for nighttime data only

Above deg and Below deg Elevation

Example: Setting "below" to -10 degrees selects data for which the sun is at least 10 degrees below the horizon.

If the Mesospheric Ozone concentration was constant throughout the day and night, MOSAIC would not be an exciting instrument. Fortunately, the ozone level does vary, yielding the opportunity for students to make measurements at different times of the day and night. The MOSAIC GUI allows the user to filter the data in two ways: by the time of day (hour) and by sun angle.

When the data are collected at each of the MOSAIC sites (approximately every 75 seconds), they are marked with the Universal Time (UT) of the measurement. This means the times recorded are EST plus 5 hours or EDT plus 4 hours. Every day, the data are averaged into 10 minute chunks in order to reduce the file sizes and provide a manageable amount of data.

The 10-minute chunks of data are also marked with the Local Equinox Time which accounts for the seasonal variation in the time of sunrise and sunset. The concept of Local Equinox Time, or simply local time, has been derived (see MOSAIC Memo #048 at: http://www.haystack.mit.edu/edu/undergrad/VSRT/VSRT_Memos/048.pdf). Under this conversion, the sun always rises at 6:00 local time, and the sun always sets at 18:00 local time. This allows the user to select data from either day or night, without having to worry about the exact time of sunrise or sunset at the observation site on the days when data was collected. These times are listed in the data in decimal form, ranging from 0.0 to 23.99.

The user may also choose to filter the data based on the angle of the sun. In this system, the horizon is 0 degrees, overhead is +90 degrees, and the sun would be directly beneath you at -90 degrees.

Bear in mind that MOSAIC is observing a volume in the Mesosphere approximately 100 km above the earth's surface. The sun's rays will intersect that locale slightly before it reaches the horizon (as seen from an observer at ground level). The sun angle at this point is approximately -10 degrees, which would be "sunrise" and "sunset" for the Mesosphere.

Mesospheric Ozone System for Atmospheric Investigations in the Classroom

Step 3: Select spectrometer(s)

- | | | | | | | | |
|-------------------------------------|--------------------------------|-------------------------------------|--|-------------------------------------|-------------------------------|--------------------------|-----|
| <input checked="" type="checkbox"/> | Chelmsford High School, MA | <input checked="" type="checkbox"/> | Haystack Observatory, MA | <input checked="" type="checkbox"/> | Bridgewater State College, MA | | |
| <input checked="" type="checkbox"/> | Union College, Schenectady, NY | <input checked="" type="checkbox"/> | University of North Carolina at Greensboro, NC | | | | |
| <input type="checkbox"/> | SP6 | <input type="checkbox"/> | SP7 | <input type="checkbox"/> | SP8 | <input type="checkbox"/> | SP9 |

There are several MOSAIC units currently installed, and others will be brought online in the near future. The user may select as many or as few of the units as desired. Due to modest signals levels of the Mesospheric Ozone, you will reduce background noise levels if you combine the readings of several instruments.

The following are permanently installed spectrometers and are selected by default.

CHS:	Chelmsford High School, Chelmsford, MA
Ridge:	MIT Haystack Observatory, Westford MA
Bridgewater:	Bridgewater State College, Bridgewater, MA
Union:	Union College, Schenectady, NY
UNCG:	University of North Carolina, Greensboro, NC

Other spectrometers are listed as SP6, SP7, SP8, and SP9. These units may or may not be installed, or may have been used only for test observations. This page will be updated when units are permanently added to the MOSAIC network.

Step 4: Select plot type

- Ozone spectrum: above and below 80km fit together above and below 80km fit separately
- Ozone vs localtime: 60 30 20 10 minutes averaging time (turn off filters to get full range of localtime)
- Ozone vs date: 20 10 4 2 1 days averaging time modulo 1 year (use filter for nighttime data)

Select "modulo 1 year" to wrap data by year (e.g., all data taken on January 3, regardless of year, are averaged and plotted as day 3)

Format of avout.txt files

When the data are downloaded in the form of an avout.txt file, the column headings are located in the column preceding the data.

Ozone Spectrum: Data is binned into 64 channels of 9.8 kHz bandwidth, centered near the spectral line of 11.0724545 GHz. The peak energy will be in channel 32, with significant energy in channel 31 and 33. The raw data will be shown along with a smooth curve fit to the data

- Options: Above and Below 80 km fit together
 Above and Below 80 km fit separately

The frequency dependence of the signal is called line shape. The 80 km height is a line of demarcation for changes in atmospheric temperature and pressure. Models indicate that the ozone above 80 km will contribute a sharp spectral line, while the ozone below 80 km will exhibit significant broadening (pressure broadening). The user may choose curve fitting of the ozone layers together or separately.

2 sets of units

Depending on the data requested, the quantity used to characterize mesospheric ozone intensity will vary. In spectral plots, the data plotted are antenna temperatures, measured in milliKelvins (mK). This is a unit used by radio astronomers to characterize signal strength, and can be thought of as the temperature of a blackbody emitting the equivalent signal at the frequency being studied. In ozone vs. time plots, the data are in terms of a volume mixing ratio, measured in parts per million. Clearly the two methods of measuring are related, since both are a measure of the strength of the signal. The specifics of the conversion can be found in MOSAIC Memo #069.

Mesospheric Ozone System for Atmospheric Investigations in the Classroom

What you see (graphical output)

The x-axis is frequency, with 0.0 = 11.0725 GHz (the center of the ozone line). The y-axis is antenna temperature. The data are plotted in staircase form to make clear the number of channels (64) and the bandwidth (9.75 MHz) of each. The data are automatically fit to the theoretical curve for the shape of the line. If you have selected above and below 80 km fit separately, you will see two curves fitting the data, one corresponding to the ozone above 80 km (from the mesosphere), and one corresponding to the ozone below 80 km (from the troposphere and stratosphere).

What you get (avout.txt file)

You will receive a lot of data. The columns are tab-delineated, and if you save the file, you can import it into Excel®, which knows how to turn the text file into a spreadsheet. The name for each column is in the preceding column.

The time/date columns (**year**, **day**, **hour**, and **minute**) are self explanatory. It is important to note these times are in Universal Time (UT). These data will be listed for every 10 minutes in the window you requested.

num_rec displays the number of spectra averaged into that 10 minute period. The MOSAIC spectrometer outputs data approximately once every 75 seconds, which means there will be 8 or 9 spectra in any given 10 minute block.

sun_el is the sun's elevation at the location of the spectrometer at the time of the spectrum. This is at ground level, and since the mesosphere is much higher (80 km above Earth's surface), the sun sets later and rises earlier than it does on the surface.

tpwr is the total power measured by the system during that 10 minute period, measured in dB.

rms is the standard deviation in the spectrum, in Kelvin, after subtracting the average value.

ltm is the "equinox" local time at the location of the spectrometer. This is an artificial local time that makes 6.0 sunrise and 18.0 sunset every day, regardless of the season. This is so that you can average data from multiple days in different parts of the year without introducing error due to the differences in the start of the day.

spect__ is the designation for the spectrometer that collected the data. Each of the 5 operational MOSAIC units has a number, so when you see spect000, you know that spectrum was collected at Chelmsford High School. What follows are 64 columns of numbers, corresponding to the (10 minute average) spectral readout from the spectrometer at the time indicated.

Mesospheric Ozone System for Atmospheric Investigations in the Classroom

What you get (sum.txt file)

This contains the parameters for the curve automatically fit to the data displayed in the graphical output. As in the data from the avout.txt file, the name of each element is in the column preceding it.

peak is the maximum value of the curve fit to the spectrum, in milliKelvin (mK). For students trying to characterize the strength of the signal, this is probably the best number to use (if you want the results in mK).

rmsresid is the root-mean-square (an average) of the residuals of the spectrum relative to the curve fit. The larger this number is, the worse the fit of the data to the curve. If the curve were a perfect fit with no noise, the value would be zero. The value is in mK.

theory is the theoretical value of the **rmsresid** based on the system noise temperature. This would be the value of the **rmsresid** if all the error in curve fit came from random noise. In practice, the actual **rmsresid** is normally larger than theory due to systematic changes in the system or interference in the measured spectrum, which results in deviation from the expected profile.

fit_high is the peak value of the curve fit to the data, in ozone vmr measured in parts per million (ppm). This is another good way to characterize the spectrum.

fith_err is a measure of the uncertainty in the **fit_high**. It is the standard deviation of the residuals to the fitted curve.

fit_low will be equal to zero if you have selected to fit above and below 80 km together. If you have fit them separately, this will give the value of the peak of the curve fit to the below 80 km data (the curve seen in the dotted line in this type of output.)

fitl_err is a measure of the uncertainty in the **fit_low** peak. Will also be zero if you have selected to fit above and below 80 km together.

avtpwr is the average total power for the spectrum, in dB.

Following that, there will be an indication of the dates selected for the spectrum.

 **Ozone vs Local Time:** For MOSAIC data analysis with a window of one day, use this button. This is useful for watching the diurnal variations in the Mesospheric Ozone concentration.

Options:

- 60 minute
- 30 minute
- 20 minute
- 10 minute averaging time

Mesospheric Ozone System for Atmospheric Investigations in the Classroom

About the averaging

The data are averaged according to “equinox” local time, with a center value of the time listed and a time interval equal to what is selected on the interface. The system combines the spectra from all the selected spectrometers within the time ranges indicated, using the **ltm** value (the equinox local time). For example, for 20 minute averaging, the data point listed at 1.00 hour will contain the average of data from equinox local times 0:50 to 1:10, or 0.833 to 1.167.

What you see (graphical output)

Time is on the x-axis, in hours, taken from the “equinox” local time. The time will always go from 0 hours to 24 hours, with day located in the middle of the graph and night located on either side. On the y-axis is ozone volume mixing ratio, in ppmv. This is an indication of the strength of the mesospheric ozone signal. The data are automatically fit to a curve that assumes a constant value for ozone at night and during the day, with an exponential function to connect them. If you have selected above and below 80 km fit separately, you will see two graphs like this, one corresponding to the ozone above 80 km (from the mesosphere), and one corresponding to the ozone below 80 km (from the troposphere and stratosphere).

What you get (avout.txt file)

time is self-explanatory. You will see values from 0 to 24, with the number of times included depending on what time interval you averaged for. For example, if you average over 30 minutes of data, you will see 0.0, 0.5, 1.0, 1.5, etc.

fit_h gives, for each time interval, the peak of the curve fit to the spectral data, in ozone vmr in ppm. This is the same as the **fit_high** parameter provided in the sum.txt output from the spectral graph. This is just a measure of the relative strength of ozone at each time. If you have selected to fit above and below 80 km together, this is the parameter corresponding to both parts of the spectrum. If you have opted to fit them separately, it corresponds to above 80 km, or the mesospheric contribution.

err gives the uncertainty associated with the peak value in **fit_h**. This is the same as **fith_err** in the sum.txt file from the spectral output, and is the standard deviation of the residuals to the fitted curve.

fit_l will be zero if you have opted to fit data from above and below 80 km together. It will be non-zero if you have fit them separately, and equal to the peak of the curve fit to the averaged data (in ozone vmr in ppm) from below 80 km. It is the same as the **fit_low** parameter in the sum.txt file from the spectral curve fit.

err is the uncertainty associated with the peak value in **fit_l**. It will be zero if you have opted to fit above and below 80 km together.

 **Ozone vs Date:** For MOSAIC data analysis with windows longer than a day, use this button.

Options:

- 20 day
- 10 day
- 4 day
- 2 day
- 1 day averaging time
- modulo 1 year

About the averaging

The system combines the spectral data from throughout each day and from each of the spectrometers selected, averaging them to produce a spectrum. The date plotted is the center of the averaging. If you select to average over 10 days, it will take 5 days before and 5 days after the chosen start date for the first data point. The curve that would fit this spectrum is determined, and its peak value is used to characterize the strength of the ozone on this day. This graph is best seen when only nighttime data is used, since the daytime levels of ozone are so low.

What you see (graphical output)

Time is on the x-axis, in year and day of year. Ozone volume mixing ratio (in ppmv) is plotted on the y-axis, which is a measure of ozone concentration. If the modulo 1 year button is selected, all years are plotted as a function of the day of the year.

What you get (avout.txt file)

date This is the date being plotted, with the first number being the chosen start date from the GUI.

fit_h This is the peak value of curve fit to the averaged spectrum, in ozone vmr in ppm. If you have opted to fit above and below 80 km together, this is the parameter corresponding to all parts of the atmosphere observed. If you fit them separately, it corresponds to above 80 km, or the mesosphere.

err is the uncertainty associated with the **fit_h** peak value.

fit_l will be zero if you have opted to fit above and below 80 km together. If you have fit them separately, this will correspond to the peak value of the curve corresponding to the data from below 80 km.

err is the uncertainty associated with the **fit_l** peak value.

Mesospheric Ozone System for Atmospheric Investigations in the Classroom

Advanced Options: (requires a detailed knowledge of the spectrometer) [see MOSAIC memos](#)

- include total power in plots vs time
- include data with high T_{sys} (probably due to rain)
- plot only total power vs time for selected time range
- plot cal freq. vs time for start day
- plot total power vs time for start day (high res)
- high resolution spectrum
- use T_{sys} correction
- solve for Mesopause temperature

Explanations of these buttons will not be provided here in the MUG. These advanced options are left as exercises for the adventurous, who should read through the MOSAIC memo files on the Haystack Observatory web site for further details.

http://www.haystack.mit.edu/edu/undergrad/VSRT/VSRT_Memos/memoindex.html