

VSRT ASSEMBLY MANUAL

Dr. Martina B. Arndt
Department of Physics
Bridgewater State College (MA)

Based on work by
Dr. Alan E.E. Rogers
MIT's Haystack Observatory (MA)

With contributions from:
Robert Schweitzer '09
Bridgewater State College (MA)

August, 2009

THE VSRT: ASSEMBLY

The Very Small Radio Telescope (VSRT) is an inexpensive, portable, easily assembled instrument made out of off the shelf parts. Included in this section are an equipment list and detailed assembly instructions along with a few trouble shooting tips. A complete series of Memos related to the VSRT are available online as well (VSRT_Team, VSRT Memos).

EQUIPMENT: HARDWARE LIST

The VSRT is made up of Ku 12 GHz Low Noise Block Downconverter Feeds (LNBFs – i.e. two recycled Direct TV receivers), power supplies, inline amplifiers, a diode detector and a USB video frame grabber to digitize the data for processing in a PC. Table 1 lists the full part list (Rogers & Pratap, VSRT Memo #47, 2009).

When the VSRT is fully assembled, without the satellite dishes, and attached to a computer, it looks something like the set up in Figure 1.

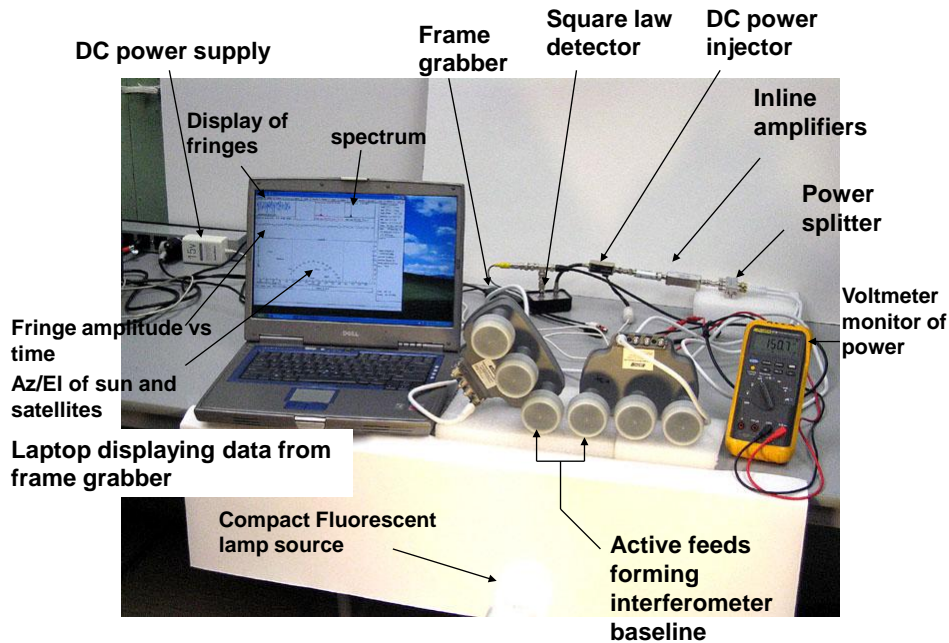

Figure 1: Components of the VSRT interferometer

Table 1: Full parts list for the VSRT

Description	Part Number	Number required	SuggestedSource	Approximate price for each	Note
18"x20" DIRECTV Satellite Dish Antenna with 3 dual LNBs	WNC AU2-F1 or equiv	2	Amazon.com	\$68	1
4-way splitter DC pass all ports	Channel vision HS-4	1	Amazon.com	\$10	
In-line amplifier and power injector	15-1170	1	RadioShack	\$37	
In-line amplifier	CAE-9220	1	Amazon.com	\$7	
CompUSA Video Grabber USB 2.0	SKU381714	1	CompUSA	\$50	
15v AC-to-DC Power Adapter	273-1691	1	RadioShack	\$25	
3-amp barrel diodes 1N5404 (3 in pack)	276-1114	1	RadioShack	\$2	
male-to-male "F" connector adapter	278-219	2	RadioShack	\$3	
"F" connector to BNC jack adapter	278-277	1	RadioShack	\$5	
Coaxial Adapter, BNC female /RCA male	278-250	1	Radio Shack	\$5	
Detector diode 1N6263	497-2508-1-ND		Digikey.com	\$1	
M61235 6' RG-6 cables with F connectors	M61235	2	Amazon.com	\$3	
6-ft RG-59 Coax cable (BNC)	278-990	1	Radioshack	\$8	
1/4 watt resistor assortment	271-312	1	RadioShack	\$12	
100pf capacitor	272-123	1	RadioShack	\$2	
project enclosure (3x2x1)	270-1801	1	RadioShack	\$2	
BNC chassis-mount Jack	Neutric 092-262	2	Amazon.com	\$14	
JcommUSB API	Personal Edition	1	Icaste.com	\$35	
GE Biax 27W or equivalent compact fluorescent lamp	FLE27QBX/2/5w	2	Ace hardware	\$13	
Sub total				\$403	
Shipping est.				\$80	
Total				\$483	

Notes:

1. Only one LNB is required so if 3 dual LNBs are no longer available other units like TERK TRK-S2 are available.
2. The CompUSA video Grabber USB 2.0 is only occasionally available on ebay.

The GrabBee X+ USB 2.0 audio/video grabber "deluxe" from Amazon is compatible. Approximate price \$60. The unit comes from www.ruby-electronics.com and doesn't have a part number on the box. However, the Ruby Web site lists a parts number as Sku: GRBEEDX-001 and it also specifies the chips Philips SAA7113 and Empia 2820, which are compatible with our software. Other suppliers may be found on the Internet.

Accessories:

Various accessories like camera tripods to support the fluorescent lamps, mirrors to aid in dish pointing, home made metal tape polarizing filters and other miscellaneous parts will be needed for demonstrations and experiments.

ASSEMBLY

Once you have collected and identified all the parts for the VSRT, you can follow the schematic in Figure 2 to assemble it. Several of the steps are detailed below, along with photos to help guide you. Note that you will need to do some soldering.

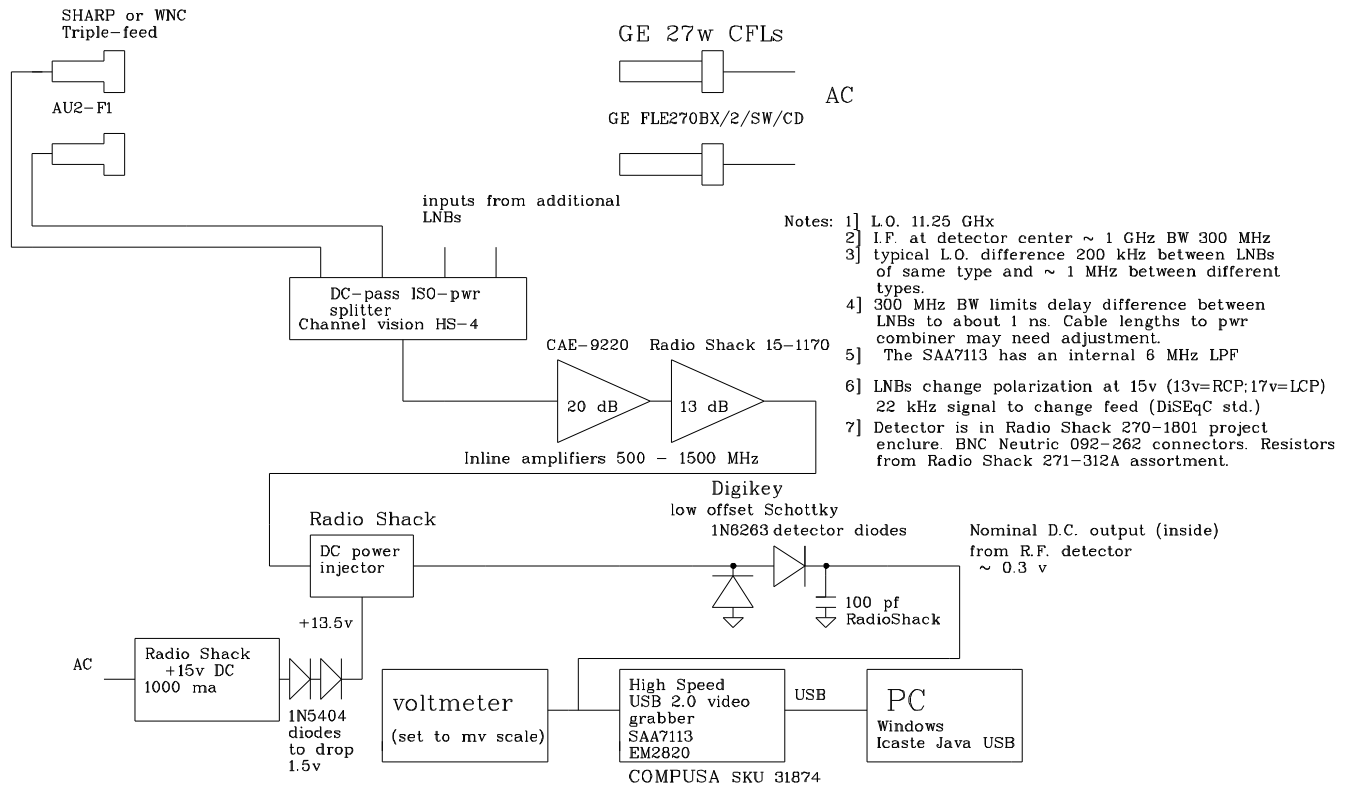
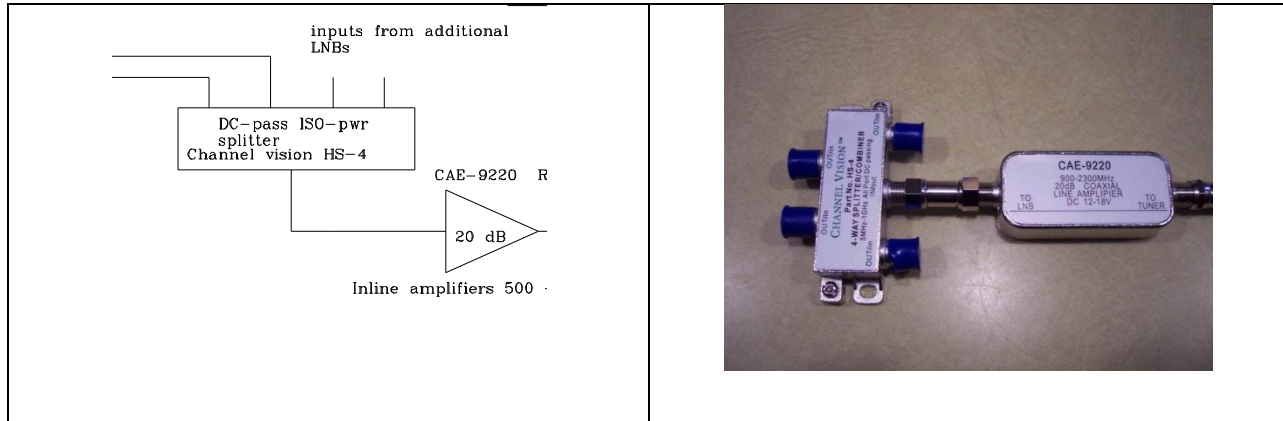
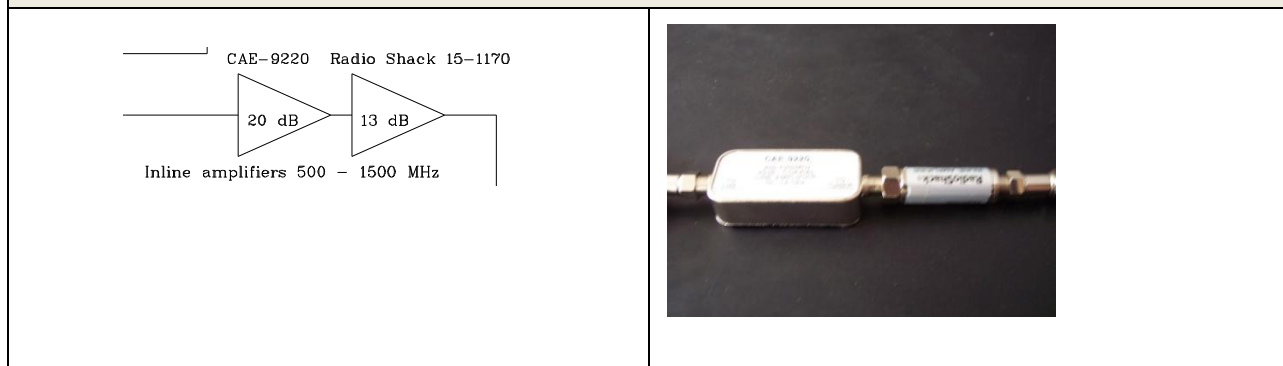

Figure 2: Schematic of the VSRT

Following are figures and instructions to assemble specific parts of the schematic shown in Figure 2.



The LNBS connect via coaxial cables into the cable splitter, and the splitter connects to the 20 dB inline amplifier.



The 20 dB inline amplifier then connects to the 13 dB inline amplifier. The majority of these connections will be in a straight line, unlike the schematic. On both amplifiers, note the directions printed on them and hook them up accordingly. Where it says “to television” or “to tuner”, think of it instead “to computer”.

Be aware that the Radio Shack 13 dB inline amplifier may have a piece attached to it that says “DC BLOCK”. This piece will prevent data from getting to the computer, so it needs to be removed. If necessary, wrenches may help in the removal proves, as the connection can be rather tight.



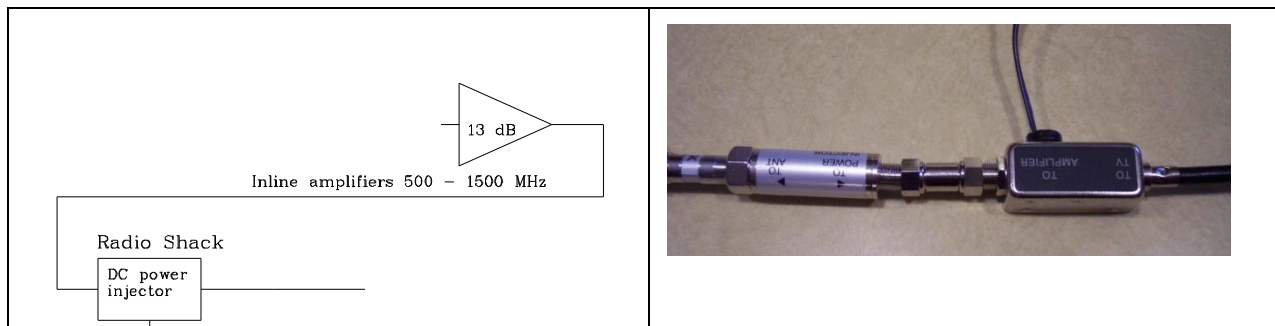

Following the two amplifiers is the DC Power Injector. The DC Power Injector needs its power supply modified.

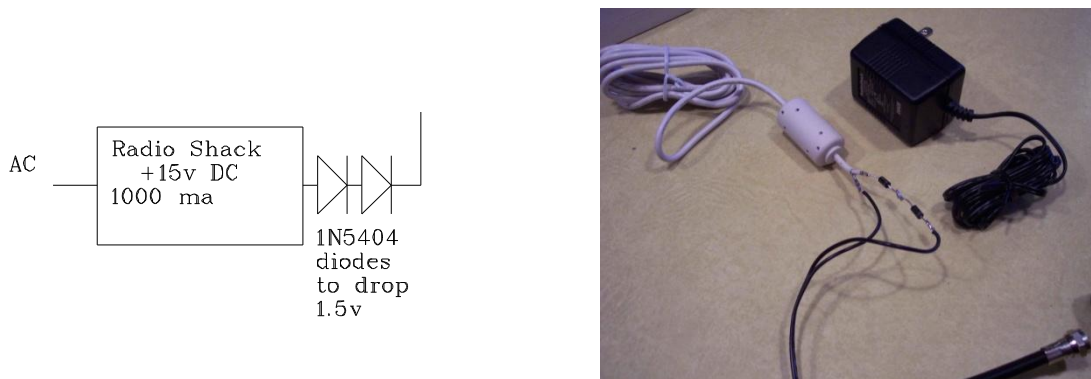

The original power supply, in black, needs to be removed from the Power injector. The 15v power supply, in white, should have its connectors cut near the end, and two LN5404 diodes are to be soldered in series from the “hot” connection (shielded wire) of the 15V power supply to the wire with the dashed white lines in the power injector; the bare wire from the 15V power supply needs to be soldered to the wire without dashed lines on it on the power injector. Be sure to cover all exposed wires with electrical tape after soldering/assembling.

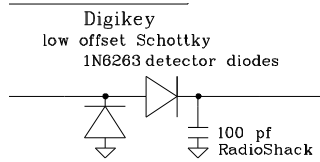

The power injector then connects to the square law detector, which needs to be assembled in the Radio Shack project inclosure. First, holes need to be drilled into the metal cover; 3/8" drill bits seem to be a perfect fit for the coaxial connectors.



The coaxial connectors need to be secured in the holes, and two Schottky 1N6263 diodes and the 100 pF capacitor need to be soldered to connect them. One diode goes to ground (the cover itself), and the capacitor connects to ground. Be careful with the directions of the diodes; they only allow information to pass in one direction, so if one is soldered backwards, the detector will not work.

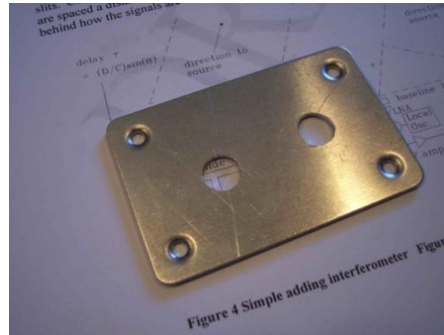

Note that the input/output connectors on the finished square law detector are labeled according to the diodes' directions: the capacitor should be on the output side, and the diode coming from ground should be the input direction.



Now that the square law detector is set up, it can be connected in our circuit. The connection goes from the power injector to the input of the square law detector, and the output of that connects to a female coaxial-to-coaxial adapter.

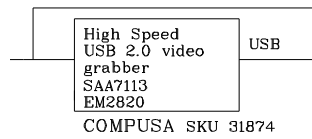

Connecting the square law detector to the USB Video Grabber involves three adapters connected to one another. The first is the female coaxial-to-coaxial, followed by a male coaxial to female BNC adapter, and finally the male BNC to male RCA adapter.

The male RCA adapter (the rightmost adapter) connects to the yellow connection on the USB Video grabber (red and white are generally used for audio, and as such are not used for the VSRT), which finally connects to the computer via USB.

The function of the frame grabber is to perform a high-speed analogue to digital conversion. Please note that you should NOT install the software that comes packaged with the frame grabber. More information on the correct software is online (VSRT_Team, VSRT Software) at haystack.mit.edu.

- d. With one LNBF at a time check that the power increases when the CFL is brought close. If you can run the setup outside point the LNBF at the sky and observe the power. Compare your results with the typical readings given in VSRT memo #17 (Rogers, VSRT Memo #17, 2007).
- e. Make sure the cable lengths from the LNBFs to the power combiner are equal.
- f. Check that the L.O. difference is not too close to zero. Look close to the zero frequency end of the spectrum for the “beat”. Heat one LNBF which will cause its L.O. frequency to change to see if you can move a beat out of the noise at the low end of the spectrum.

Antenna pointing.

When trying to point a dish at the Sun or other source use a mirror stuck to the center of the dish as a pointing guide. A flat 38mm×38mm mirror from Edmund Scientific part number 3052323 (Scientific, 2009) is a good choice.

Square Law detector

The detector will only take the square of the waveform over a relatively narrow range. In most cases the inline amplifier which comes with the Radio Shack power injector plus one additional amplifier will provide about the right level (between 30 to 250 mV see VSRT memo #7 (Rogers, VSRT Memo #7, 2007)) as measured with a voltmeter with the load of the frame grabber connected. If you are not in the square law range, experiments for which you measure levels will be in error while those which rely on looking for a null will not be affected.

1] Alignments

The beam patterns of the LNBFs should be measured and taken into account when necessary.

2] Delay compensation

To satisfy the “white fringe” condition the path lengths should be close to one half of the inverse bandwidth or better. In some experiments it may be necessary to make the paths more equal by adjusting the cable lengths to one LNBF or using an optional filter to narrow the I.F. Bandwidth.

WORKS CITED

Rogers, A. E. (2007, April 25). *VSRT Memo #17*. Retrieved August 13, 2009, from http://www.haystack.mit.edu/edu/undergrad/VSRT/VSRT_Memos/017.pdf

Rogers, A. E. (2007, August 2). *VSRT Memo #23*. Retrieved August 13, 2009, from http://www.haystack.mit.edu/edu/undergrad/VSRT/VSRT_Memos/023.pdf

Rogers, A. E. (2007, January 31). *VSRT Memo #7*. Retrieved August 13, 2009, from http://www.haystack.mit.edu/edu/undergrad/VSRT/VSRT_Memos/007.pdf

Rogers, A. E., & Pratap, P. (2009, January 30). *VSRT Memo #47*. Retrieved August 4, 2009, from http://www.haystack.mit.edu/edu/undergrad/VSRT/VSRT_Memos/047.pdf

Scientific, E. (2009). *First Surface Flart Mirrors*. Retrieved August 13, 2009, from Edmund Scientifics: <http://scientificsonline.com/product.asp?pn=3052324&bhcd2=1250176951>

VSRT_Team. (n.d.). *VSRT Memos*. Retrieved from VSRT Memos: http://www.haystack.mit.edu/edu/undergrad/VSRT/VSRT_Memos/memoindex.html

VSRT_Team. (n.d.). *VSRT Software*. Retrieved from http://www.haystack.mit.edu/edu/undergrad/srt/SRT%20Software/SRT_software_exec.html.