

**MASSACHUSETTS INSTITUTE OF TECHNOLOGY
HAYSTACK OBSERVATORY
WESTFORD, MASSACHUSETTS 01886**

22 September 2008

Updated 11 June 09

*Telephone: 978-692-4764
Fax: 781-981-0590*

To: SRT Group
From: A.E.E. Rogers
Subject: Reducing emissions from the SRT

The SRT, with the digital receiver, which was introduced in 2000, uses a high side local oscillator with an I.F. frequency of 800 kHz. While the local oscillator leakage is relatively weak compared with unwanted emissions from many other electronic devices like PCs. However, the L.O. leakage can result in Radio Interference (RFI) with other sensitive systems operating in close proximity to the SRT. The current level of emission can be as high as -70 dBi. This level can be reduced by more than 30 dB by ensuring a better electrical seal of the receiver box cover. In addition the radiated power can be reduced to below -120 dBi by adding copper tape to further improve the leakage from the box and replacing the preamp with a new preamp with greater reverse isolation whose circuit is shown in Figure 1.

The new preamp has the following characteristics:

Gain	30 dB
Reverse isolation	65 dB
Noise temperature	70 K
3 dB bandpass	1385-1440 MHz
L.O. leakage measured on input port while connected to SRT digital receiver	-120 dBm

If the VSRT control computer is not in a shielded room some shielding of the PC may be required. Any L.O. leakage which travels down the coax cable and get emitted out of the ground controller can be eliminated by adding a low pass filter (mini circuits BLP-600+ is a good choice) to the coax output of the ground controller. If the coax is a single shield RG-6 put the filter on the output of the receiver, otherwise use double shielded coax to reduce the leakage out of the cable.

To summarize:

To reduce L.O. emissions to a very low level

- 1] Seal the receiver box with copper tape
- 2] Use a high reverse isolation preamp
- 3] Shield the control PC and add low pass filter to coax if needed.
- 4] Use double or quad shielded RG-6

For assistance in reducing the RFI from the SRT at radio astronomy facilities please contact arogers@haystack.mit.edu.

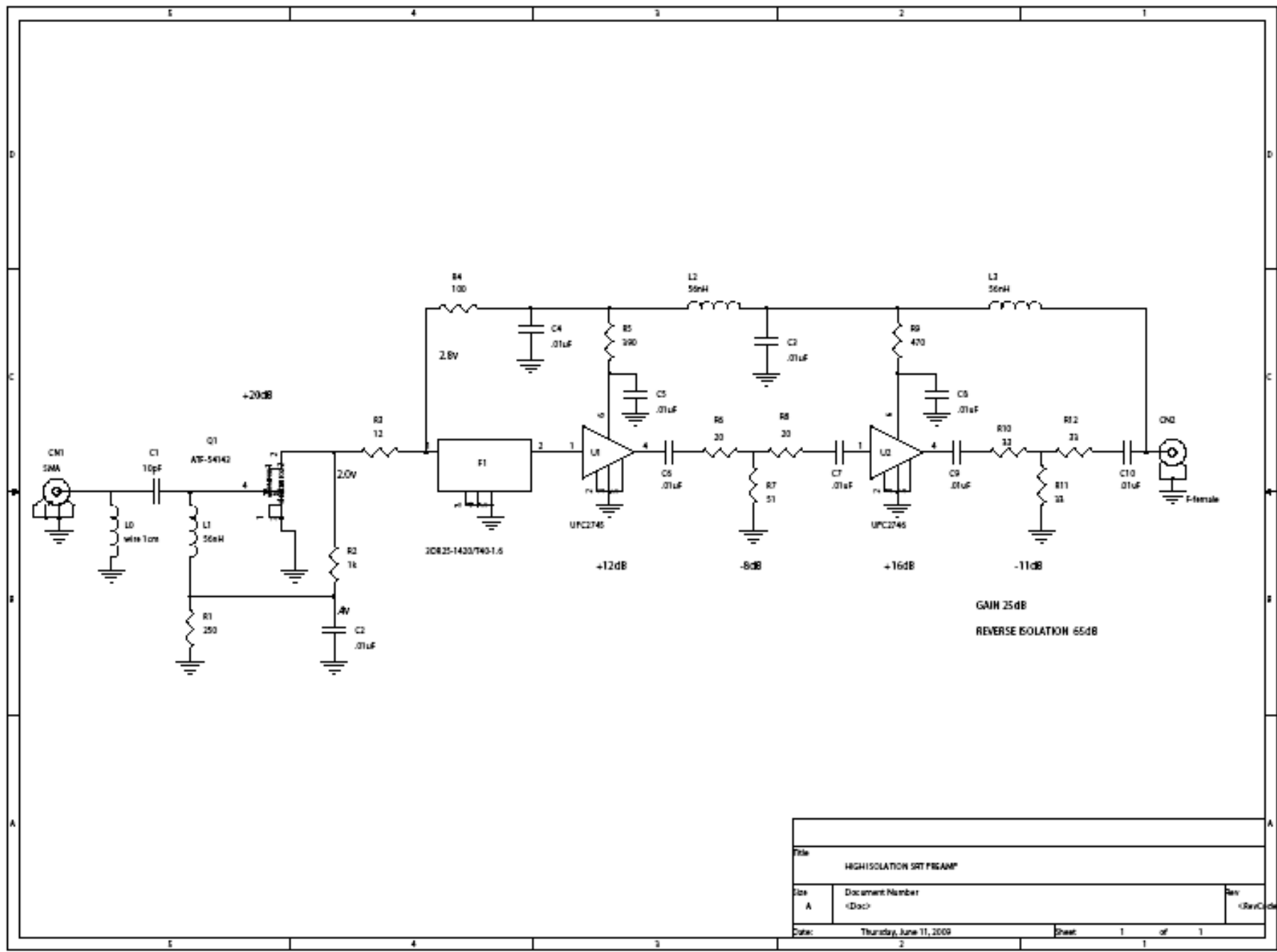

File		HIGH ISOLATION SRT PREAMP	
Size	Document Number	Rev	
A	<Doc>	<RevCode>	
Date:	Thursday, June 11, 2009	Sheet:	1 of 1

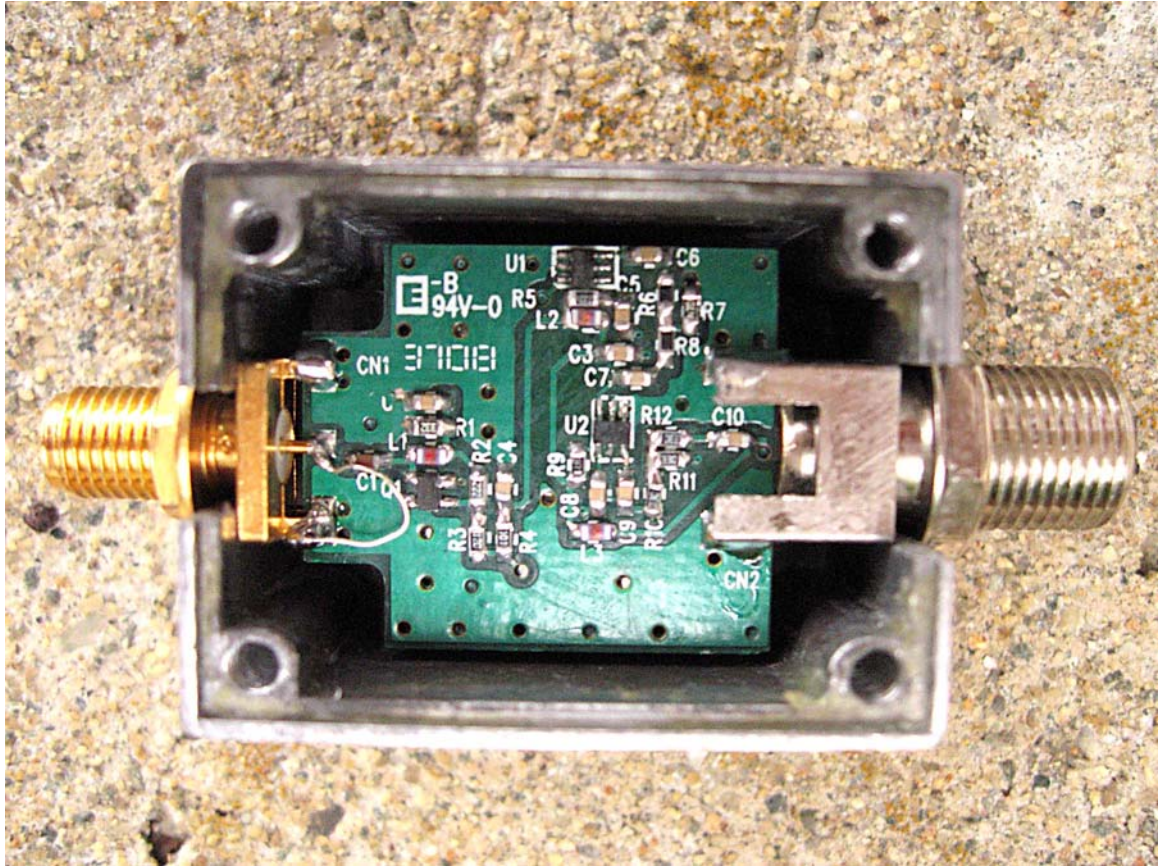

	value	qty.	ref.des.	manufacturer	part	vendor	vendor part
1	10 pf	1	c1	Panasonic-ECG	ECJ-1V1H100D	Digikey	PCC100CVCT-ND
2	0.01 uf	9	c2 c3 c4 c5 c6 c7 c8 c9 c10	Panasonic-ECG	ECJ-1VF1H103K	Digikey	PCC1784CT-ND
3	250	1	R1	Panasonic-ECG	ERJ-3GEYJ251V	Digikey	P250GCT-ND
4	1000	1	R2	Panasonic-ECG	ERJ-3GEYJ102V	Digikey	P1.0KGCT-ND
5	12	1	R3	Panasonic-ECG	ERJ-3GEYJ120V	Digikey	P12GCT-ND
6	100	1	R4	Panasonic-ECG	ERJ-3GEYJ101V	Digikey	P100GCT-ND
7	390	1	R5	Panasonic-ECG	ERJ-3GEYJ391V	Digikey	P390GCT-ND
8	470	1	R9	Panasonic-ECG	ERJ-3GEY471V	Digikey	P470GCT-ND
9	33	3	R10 R11 R12	Panasonic-ECG	ERJ-3GEY330V	Digikey	P33GCT-ND
10	20	2	R6 R8	Panasonic-ECG	ERJ-3GEYJ200V	Digikey	P20GCT-ND
11	51	1	R7	Panasonic-ECG	ERJ-3GEYJ510V	Digikey	P51GCT-ND
12	56 nH	3	L1 L2 L3	Panasonic-ECG	ELJ-RF56NJFA	Digikey	PCD1982CT-ND
13	ATF-5143	1	Q1	Agilent	ATF-5143	Digikey	516-1573-2-ND
14	UPC2745	1	U1	NEC	UPC2745	Digikey	UPC2745TB-ACT-ND
15	UPC2746	1	U2	NEC	UPC2746	Digikey	UPC2746TB-ACT-ND
16	1420	1	F1	K&L Microwave	3DR25-1420/T40-1.6	K&L Microwave	3DR25-1420 / T40-1.6
17	box	1		Pomona	3754	Newark	34F1263
18	SMA	1	CN1	Johnson	142-0701-871	Allied	528-1996
19	PCB F-conn	1	CN2	Cui Stack	BA-1210	Digikey	CP-1210-ND
20	wire	1	L0	1cm long 30 awg			
21	F male/male	1		Cui Stack	BA2010	Digikey	CP-2010-ND
22	absorber	1		absorber for top			

Parts for high isolation preamp

aeer 11 June 09