

MASSACHUSETTS INSTITUTE OF TECHNOLOGY

HAYSTACK OBSERVATORY

WESTFORD, MASSACHUSETTS 01886

Telephone: 978-692-4764

Fax: 781-981-0590

6 March 2002

TO: Distribution
FROM: Alan R. Whitney
SUBJECT: 4 March 2002 e-VLBI telecon summary

Attendees:

Lee Foster, Pat Gary, Chuck Kodak, Kevin Kranacs, Bill Wildes – GSFC

Tom Lehman, ISI

Steve Bernstein, Lorraine Prior – Lincoln Laboratory

Richard Crowley, Kevin Dudevoir, Hans Hinteregger, Arthur Niell, Alan Whitney – Haystack Observatory

This telecon is one of an ongoing series of telecons to prepare for gigabit/sec e-VLBI demonstrations between NASA GSFC and MIT Haystack Observatory using a combination of network facilities including all or part of GlowNet, Bossnet, ISI-E, SuperNet, Max and GSFC/HECN.

Status Reports

The attached figures of the e-VLBI path have been updated to reflect current status and are pretty much self-explanatory; critical status items are indicated in red. In addition, the following comments are relevant:

- Lorraine reported that the Juniper router is now in place at E7 and that connection E6 will be made as soon as administrative details are cleared, including changing IP addresses of the Haystack test machine. Will try to get this all done by end of this week. GlowNet usage for e-VLBI will be coordinated through Lorraine, who has access to the LL radar schedule; Lorraine will suggest ‘windows of opportunity’. Bossnet scheduling will be done on Bossnet activity calendar at www.ngi-supernet.org. IP-address changes will be coordinated between Kevin D. and Lorraine.
- 3rdλ on link D1 still awaiting shipment from Cisco; now scheduled to ship 8 March, but will have no effect on e-VLBI work.
- Tom reported that connection G9 is now in place at ISI-E with an OC-48 path from Lincoln Lab. Test workstation G7 is now in place. Kevin will be in touch with Tom to get the necessary details.
- Alan will send a query to Jerry asking when MAX plans to place test workstation H5 at ISI-E.
- Pat reported that GSFC has loaned MAX/UMCP a Summit 5i box (H10) which will be

connected between H7 and J5 to complete a jumbo-frame-capable path from H7 to J5; final connection of this link will be made with days to a week or so. A test workstation (J1) will likely be moved to H10 as shown in Figure 2.

- Pat reported that they have on 2-week loan from Cisco a pair of 10GigE ‘blades’ to add a 10GigE λ to the two existing GigE λ ’s on the J6 link between UMCP and GSFC Bldg 28. The link was tested by creating a GigE VLAN between Mac G4 GigE test workstations plugged into Cisco 6509’s at J5 and K1, with the VLAN connected to loop back and forth 8 to 16 times between J5 and K1, creating a traffic multiplier on the 10GigE of the same value. Results showed performance at \sim 8GigE; a similar test with back-to-back Cisco 6509’s will be done this week to see if there is any change in results. Pat will e-mail results to group. Pat estimates cost of each 10GigE blade is \$40-70K, but prices should decline rapidly; Pat will send info on 10GigE blades to Alan. Steve indicated that Jim Calvin has used a similar trick at LL to test 10GigE performance.
- The fiber of the K7/L1 link is now installed and has been tested by the installer. Summit 5i switch L2, which is currently at Bldg 28, is ready to be moved to GGAO; should happen very soon. The G4 Mac at K6 is currently being used in 10GigE testing, but will be moved in \sim 1 week to GGAO for testing. Kevin will coordinate IP addresses, etc with Lee Foster and Bill Fink.
- Pat suggests using a performance tool named **mrtg** (version 2.9), which supports 64-bit counters (earlier versions had only 32-bit counters).
- Tom reported that link between ISI-E and LL may be upgraded to 10GigE, possibly sometime this summer. Additional equipment would be need to upgrade path from LL to Haystack.
- Tom indicated ISI-E does not have good connectivity to StarTap due to lack of funding; might be possible to connect to Abilene, but only on case-by-case basis for demos; would need funding to make permanent connection. Contacts might be Paul Love or Steve Corbato, both of Internet2.
- A Mark 5 system could be ready to send to GGAO in a couple of weeks.
- Pat indicated that SAN folks at GSFC note that GigE network nicely matches the speed of existing FibreChannel connections; there is some interest in creating a SAN over IP using the GigE links. Also investigating iSCSI gateway/router technology.

GigE Performance Tests

Kevin D. is working on crafting a performance test that more closely emulates the e-VLBI application; hope to have something ready to test in a couple of weeks.

Scheduling Issues

Haystack will coordinate with Steve, Lorraine and the WNS people at LL for use of Glownet. Bossnet activity calendar will be used to schedule Bossnet usage.

Action Items

Lorraine: Will inform Kevin and Alan when connection E6 is put in place.

Pat: Send 10GigE info to Alan.

Kevin: Will coordinate with Lorraine, Tom and Lee to get IP addresses and accounts on test workstations.

Next telecon

Next telecon will be Monday, 25 March 2002 at 2 pm.

xc: Steve Bernstein, LL
Jim Calvin, LL
Lorraine Prior, LL
Leslie Weiner, LL
Herbert Durbeck, GSFC
Lee Foster, GSFC
Pat Gary, GSFC
Chuck Kodak, GSFC
Kevin Kranacs, GSFC
Paul Lang, GSFC
Aruna Muppalla, GSFC
Bill Wildes, GSFC
Dan Magorian, UMCP
Tom Lehman, ISI
Jerry Sobieski, Max
Richard Crowley, Haystack
Kevin Dudevoir, Haystack
Hans Hinteregger, Haystack
Arthur Niell, Haystack
Joe Salah, Haystack

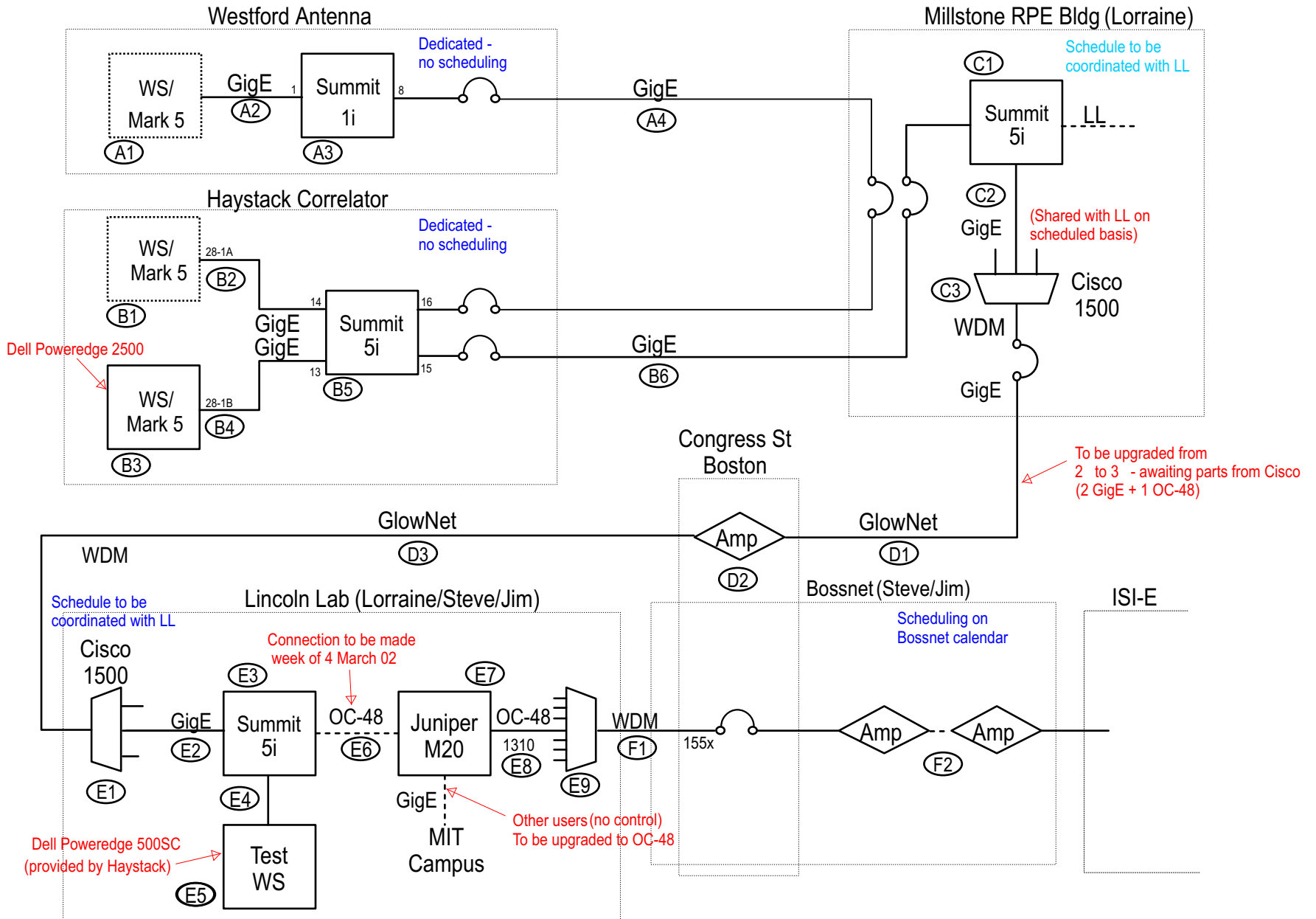

Figure 1: e-VLBI Path - Haystack to ISI-E

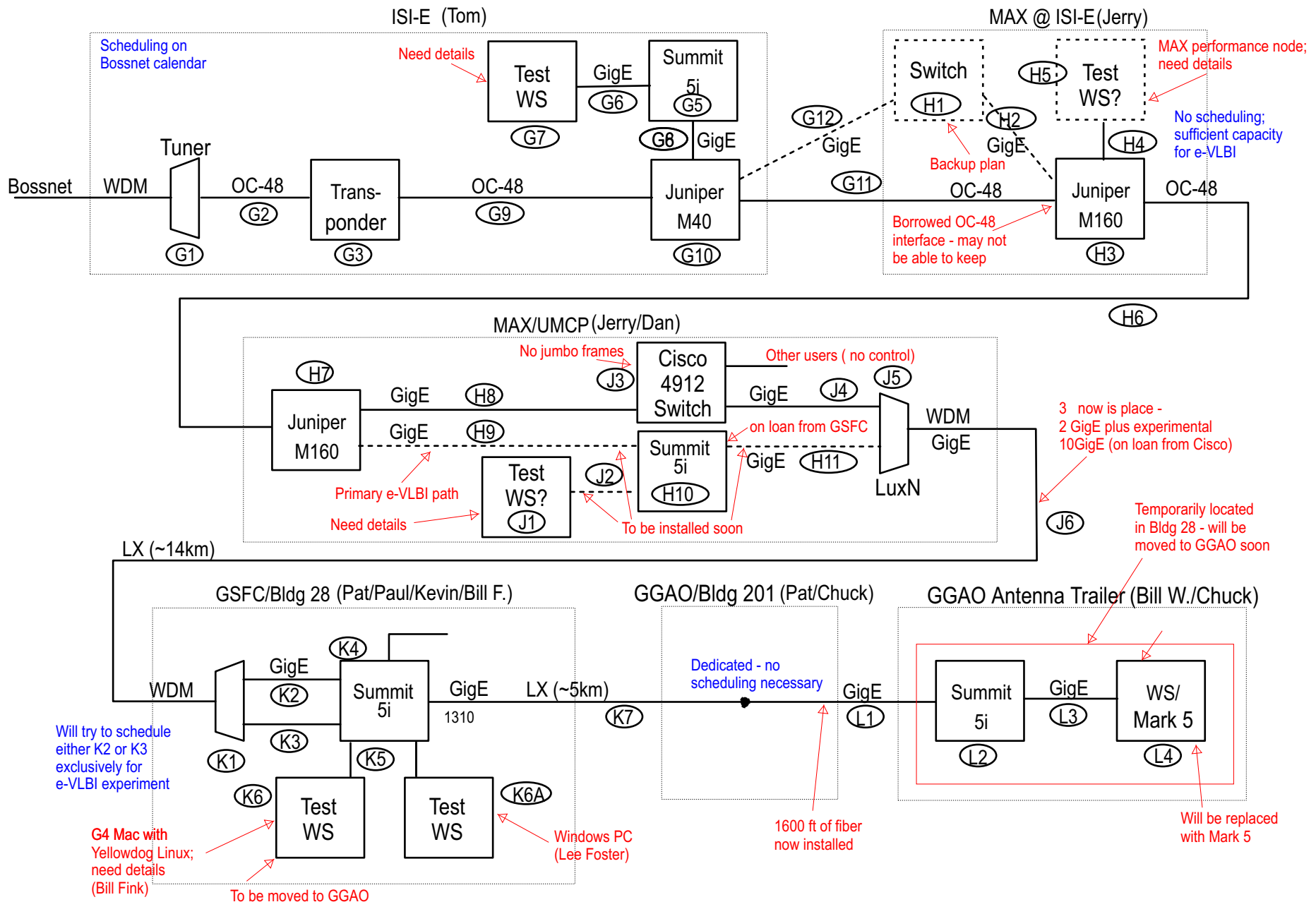

Figure 2: e-VLBI Path - ISI-E to GSFC/GGAO