

MASSACHUSETTS INSTITUTE OF TECHNOLOGY

HAYSTACK OBSERVATORY

WESTFORD, MASSACHUSETTS 01886

Telephone: 978-692-4764

Fax: 781-981-0590

28 March 2002

TO: Distribution
FROM: Alan R. Whitney
SUBJECT: 25 March 2002 e-VLBI telecon summary

Attendees:

Lee Foster, Pat Gary, Bill Wildes – GSFC

Tom Lehman, ISI

Steve Bernstein, Lorraine Prior – Lincoln Laboratory

Richard Crowley, Kevin Dudevoir, Hans Hinteregger, Alan Whitney – Haystack Observatory

This telecon is one of an ongoing series of telecons to prepare for gigabit/sec e-VLBI demonstrations between NASA GSFC and MIT Haystack Observatory using a combination of network facilities including all or part of Glownet, Bossnet, ISI-E, SuperNet, Max and GSFC/HECN.

Status Reports

The attached figures of the e-VLBI path have been updated to reflect current status and are pretty much self-explanatory; critical status items are indicated in red. In addition, the following comments are relevant:

- Tom reported that ISI-E to Bossnet is expected to be updated to 10GigE by sometime this summer under a 50-50 share arrangement with NSF and Nortel. This effort is being coordinated with Peter Schultz at Lincoln. Adding 10GigE to Haystack/LL link will require quite a bit of additional equipment (not funded).
- Lorraine reported that routing on Juniper (E7) for e-VLBI was not working, apparently due to configuration problems. She will work with Tom to resolve.
- Lorraine reported that Alpine 3804 switch has been added at E11. This switch will eventually replace switch E3. Kevin's tests show Alpine box has similar performance to Summit 5i.
- Tom will create account on G7 (dual-processor Alpha Linux) for testing.
- Lorraine reported that connection E6 has been made, but will be normally be dis-connected except for e-VLBI experiments. First opportunity for testing will be this coming Wednesday morning.
- Pat reported that H11 and J2 connections should be in place within ~1 week, H9 within next 2 weeks.
- Lee reported that loaned Cisco 10GigE equipment has been sent back to Cisco.

- Lee reported that fiber to GGAO has now been tested with loopback with good results.
- Test workstation at K6 will be moved to GGAO within next week, as well as switch L2. Bill gave permission to hold on to test workstation B3 for a while longer so high-performance testing from Haystack can continue.
- Lee reported that test workstation at K6A still needs work to be put into shape; Lee will ask Bill Fink to assist.
- Lorraine will get necessary information from Tom to make entries in Bossnet calendar at <http://www.ngi-supernet.org/>.
- Pat indicated that actual link length from GSFC Bldg 28 to GGAO is 7.75km.

Security

There is some concern at Haystack about possible security implications of the network connections necessary to control the correlators and Mark5 machines, particularly since the correlator control computer (B11) is attached to the local Haystack network which has Internet access (through the Haystack firewall). Steve and Lorraine indicated that GigE network through Lincoln is isolated during e-VLBI, so that this should not be a concern.

Kevin will lead effort to understand the necessary network connections for correlators and Mark 5 control. Alan will include these connections in updated network diagrams. [Result of that effort indicates that we should be able to control Mark 5's through GigE network with little impact on data since control data rate is very low; diagram has been updated. Correlator control computer will connect through copper port on switch B5 at Haystack, which should auto-negotiate down to 100 Mbps. This has been added to the attached diagrams.]

Tom indicated that the 141.73.x.x research network space is pretty much unroutable on the Internet, so he keeps everything related to the research networks pretty much separate from production networks.

Action Items

Tom and Lorraine: Resolve Juniper M20 (E7) routing issues.

Kevin: Get account information for test workstation G7 from Tom and test workstation K6 from Lee.

Pat: Make connections H11 and J2 within next week, H9 within two weeks.

Lee: Move test workstation K6 and switch L2 to GGAO and connect.

Richard: Test Summit 1i copper port for fallback to 100Mbps.

Alan: Add Mark 5 and correlator control connections to diagrams (done).

Next telecon

Next telecon will be **Thursday, 18 Apr 2002** at 2 pm.

xc: Steve Bernstein, LL
Jim Calvin, LL
Lorraine Prior, LL
Leslie Weiner, LL
Herbert Durbeck, GSFC
Lee Foster, GSFC
Pat Gary, GSFC
Chuck Kodak, GSFC
Kevin Kranacs, GSFC
Paul Lang, GSFC
Aruna Muppalla, GSFC
Bill Wildes, GSFC
Dan Magorian, UMCP
Tom Lehman, ISI
Jerry Sobieski, Max
Richard Crowley, Haystack
Kevin Dudevoir, Haystack
Hans Hinteregger, Haystack
Arthur Niell, Haystack
Joe Salah, Haystack

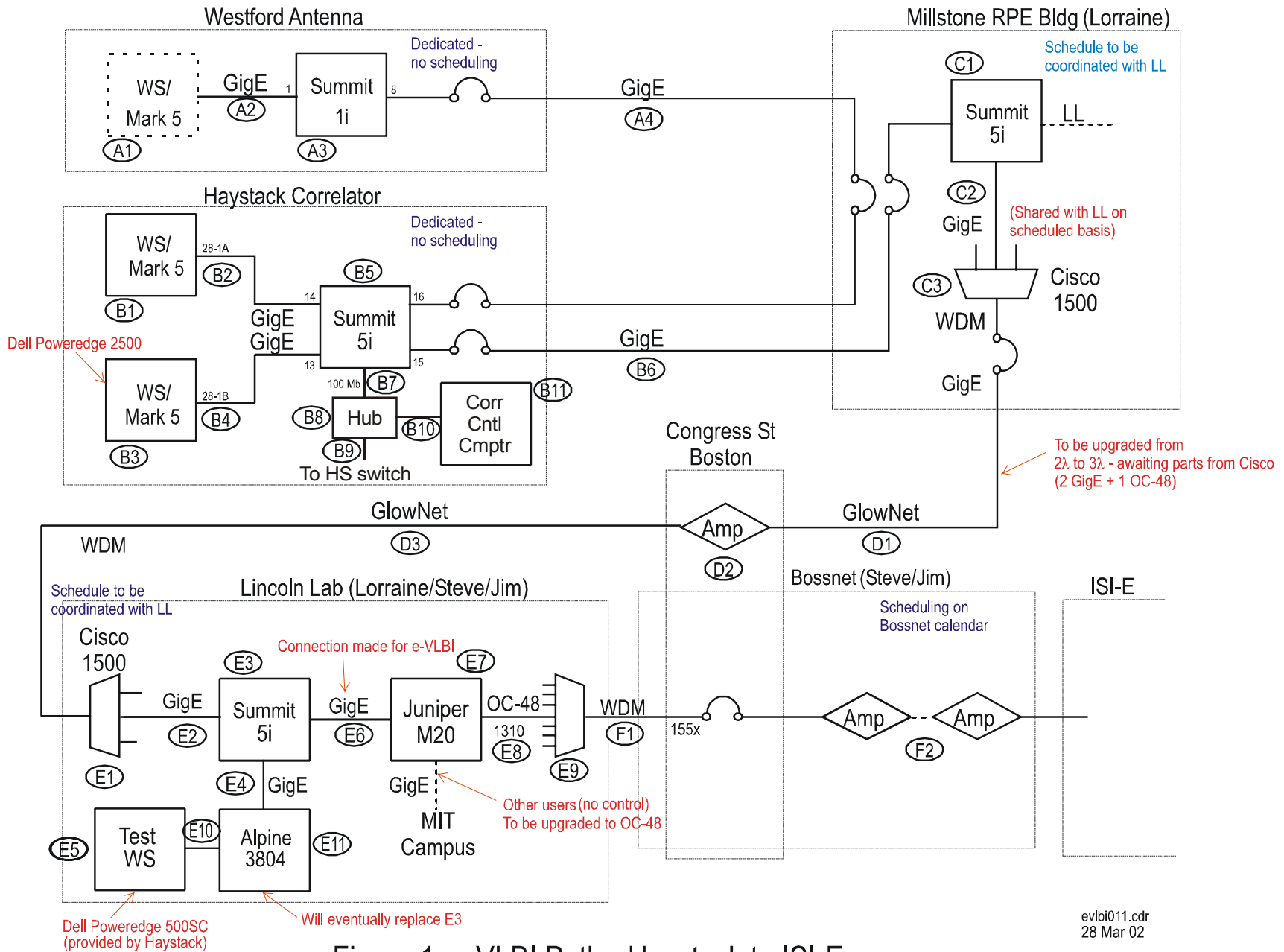
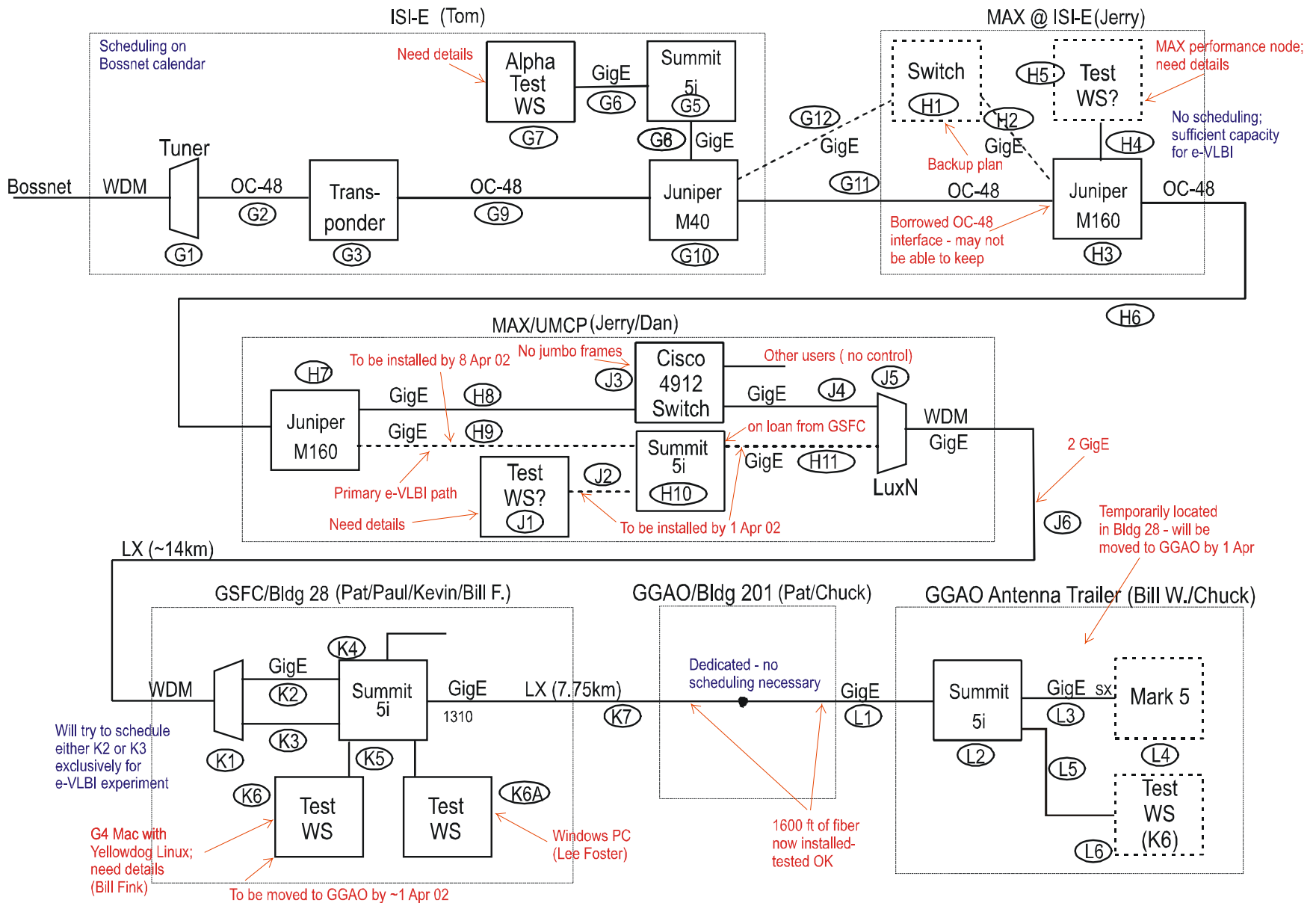

Figure 1: e-VLBI Path - Haystack to ISI-E

evlbi011.cdr
28 Mar 02



evlbi012.cdr
28 Mar 02

Figure 2: e-VLBI Path - ISI-E to GSFC/GGAO