

**MASSACHUSETTS INSTITUTE OF TECHNOLOGY**

**HAYSTACK OBSERVATORY**

*WESTFORD, MASSACHUSETTS 01886*

*Telephone: 978-692-4764*  
*Fax: 781-981-0590*

18 April 2002

TO: Distribution  
FROM: Alan R. Whitney  
SUBJECT: 18 April 2002 e-VLBI telecon summary

Attendees:

Lee Foster, Pat Gary, Chuck Kodak, Bill Wildes – GSFC

Tom Lehman, ISI

Steve Bernstein, Lorraine Prior – Lincoln Laboratory

Richard Crowley, Kevin Dudevoir, Hans Hinteregger, Arthur Niell, Alan Whitney – Haystack Observatory

This telecon is one of an ongoing series of telecons to prepare for gigabit/sec e-VLBI demonstrations between NASA GSFC and MIT Haystack Observatory using a combination of network facilities including all or part of GlowNet, Bossnet, ISI-E, SuperNet, Max and GSFC/HECN.

Status Reports

The attached figures of the e-VLBI path have been updated to reflect current status and are pretty much self-explanatory; critical status items are indicated in red. In addition, the following comments are relevant:

- Lorraine reported that the Summit 5i at C1 and E3 have been replaced with Alpine 3804's and a third  $\lambda$  has been added to the D1/D3 link. E11 no longer exists; test workstation E5 now connects directly to E3. Because one of LL radars is currently down for maintenance, e-VLBI can temporarily have a dedicated  $\lambda$  for testing (til mid-May 2002), which is much appreciated and should help speed up testing.
- Tom reported some possible problem with one of the Bossnet transponders. Tom and Steve will consult with Peter Schultz at LL regarding this issue.
- Steve reported that link F1 was severed on 9 April due to a car hitting a power pole in Somerville, MA. NStar has slightly re-rerouted the link between LL and 230 Congress St. Steve does not believe this is related to the possible Bossnet problem.
- Kevin reported UDP transfer from Haystack to ISI-E (G7) of ~850-900 Mbps with ~0.5% drop rate; UDP has not yet been tried from ISI-E to Haystack. Above 900 Mbps, drop rate rises quickly; at 980 Mbps, drop rate increases to ~5-7% and is quite repeatable. TCP throughput is often <100 Mbps, though occasionally has climbed to as high as 400

Mbps. Kevin has sent Tom a list of symptoms.

- Tom will work with Kevin next week to try to resolve the poor TCP performance between Haystack and ISI-E. Two different workstations (one dual Pentium and one dual Alpha) at ISI-E have been involved in the tests, both showing similar performance. Tom suspects some tweaking is needed.
- Pat reported that H9/H11 link will be in place by 26 April; H9 connection to H7 (Juniper M160). To make this link, Jerry Sobieski will retrieve an interface (cost ~\$25K!) currently at ISI-E which he has agreed to put into H7 for these e-VLBI tests.
- Pat will get details on test workstation at J1 from Jerry.
- Testing from Haystack to GSFC/Bldg 28 can be conducted through the H8/J4 link through the Cisco 4912 (J3), but at reduced performance since the 4912 does not support jumbo frames. Workstation at K6 position can be used for this purpose.
- Pat reported that test workstation at K6 will be moved to GGAO by 26 April. Position at K6 can probably then be 'backfilled' with another (as yet unidentified) G4 Mac test workstation. Haystack would like to hold onto Bill Wildes Dell test workstation (currently at B3) for a while longer since Haystack has no other suitable machine at the moment.
- Alan asked anyone with recommendations for a good PC motherboard for supporting GigE; must also support 64-bit/66-MHz PCI. CPU in current motherboard (Dell motherboard with 1 GHz P3) nearly saturates during simple performance testing and must be upgraded.

#### e-VLBI workshop at Haystack Observatory

A 2-day international e-VLBI workshop was held at Haystack Observatory on 8-9 April (last week), attended by ~70 VLBI and network experts. Meeting information and presentations are available on-line at <http://web.haystack.mit.edu/haystack/vlbisystems.html>; a meeting summary will be posted soon at the same address.

#### Other

Pat suggests that we think ahead to how to keep the link alive after the conclusion of demonstration period, when loaned and borrowed equipment will inevitably have to be returned. In particular, the H9 connection into H7 (Juniper M160) and the G11 connection into H3 (Juniper M160) are temporary and need to be solidified with real dollars. Tom suggests we should get together with NSF and/or DARPA to establish a follow-on program to this demonstration, which may very well include procuring the equipment to replace currently loaned or borrowed pieces.

Bill Wildes indicated that Jim Fisher (NASA?) is hosting a round table discussing future directions of computing for NASA Code Y. A future round table may include high-performance network discussions, and we should keep our eyes open for this. Bill also indicated that John LaBrequé of NASA HQ is a big supporter of this e-VLBI demonstration experiment and is very interested in possibly launching a new initiative under Code Y to further e-VLBI development.

Pat suggests focusing on at least two things in future activities: 1) solidifying activities at 1 Gbps and 2) push the envelope to 10 Gbps as next generation. Tom indicated again that he expects to have 10GigE up between ISI-E and LL sometime this summer.

Pat mentioned that Gary Carter of UMBC (ex-LL) had contacted him, indicating that he (Carter) is expecting some NASA money to work on high-speed networking problems that NASA may have. When Pat mentioned the e-VLBI work, Carter was very interested and thought he (UMBC) might be able to contribute. Steve said that he recalls that Gary is oriented more toward physical-layer problems. Pat will follow up on this with Gary.

#### Action Items

*Pat:* Make connections H9 and H11 by 26 April 2002.

*Pat:* Move test workstation K6 to GGAO by ~26 April 2002.

*All:* Think about follow-on activities.

#### Next telecon

Next telecon will be **Monday, 6 May 2002** at 2 pm.

xc: Steve Bernstein, LL  
Jim Calvin, LL  
Lorraine Prior, LL  
Leslie Weiner, LL  
Herbert Durbeck, GSFC  
Lee Foster, GSFC  
Pat Gary, GSFC  
Chuck Kodak, GSFC  
Kevin Kranacs, GSFC  
Paul Lang, GSFC  
Aruna Muppalla, GSFC  
Bill Wildes, GSFC  
Dan Magorian, UMCP  
Tom Lehman, ISI  
Jerry Sobieski, Max  
Richard Crowley, Haystack  
Kevin Dudevoir, Haystack  
Hans Hinteregger, Haystack  
Arthur Niell, Haystack  
Joe Salah, Haystack

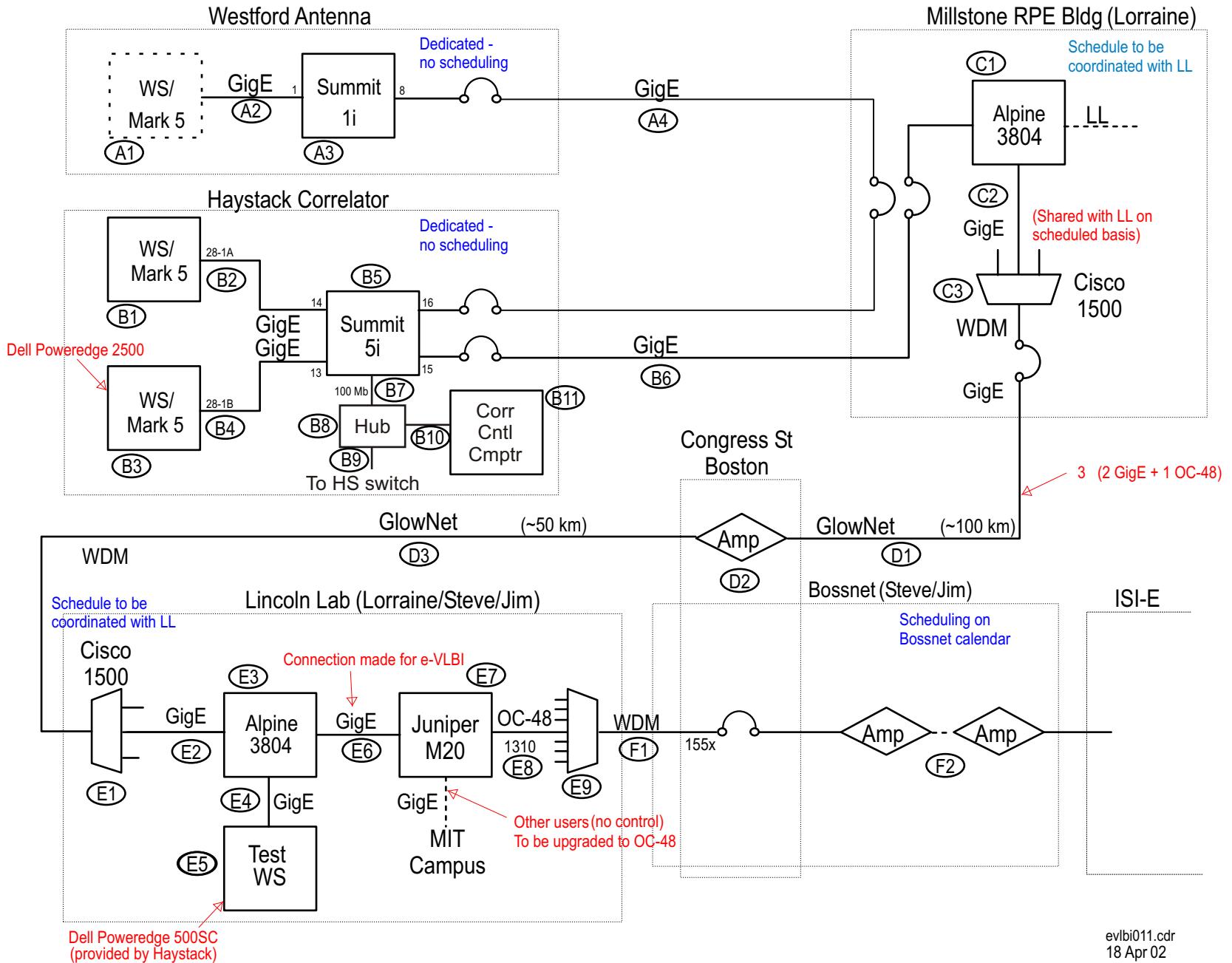

Figure 1: e-VLBI Path - Haystack to ISI-E

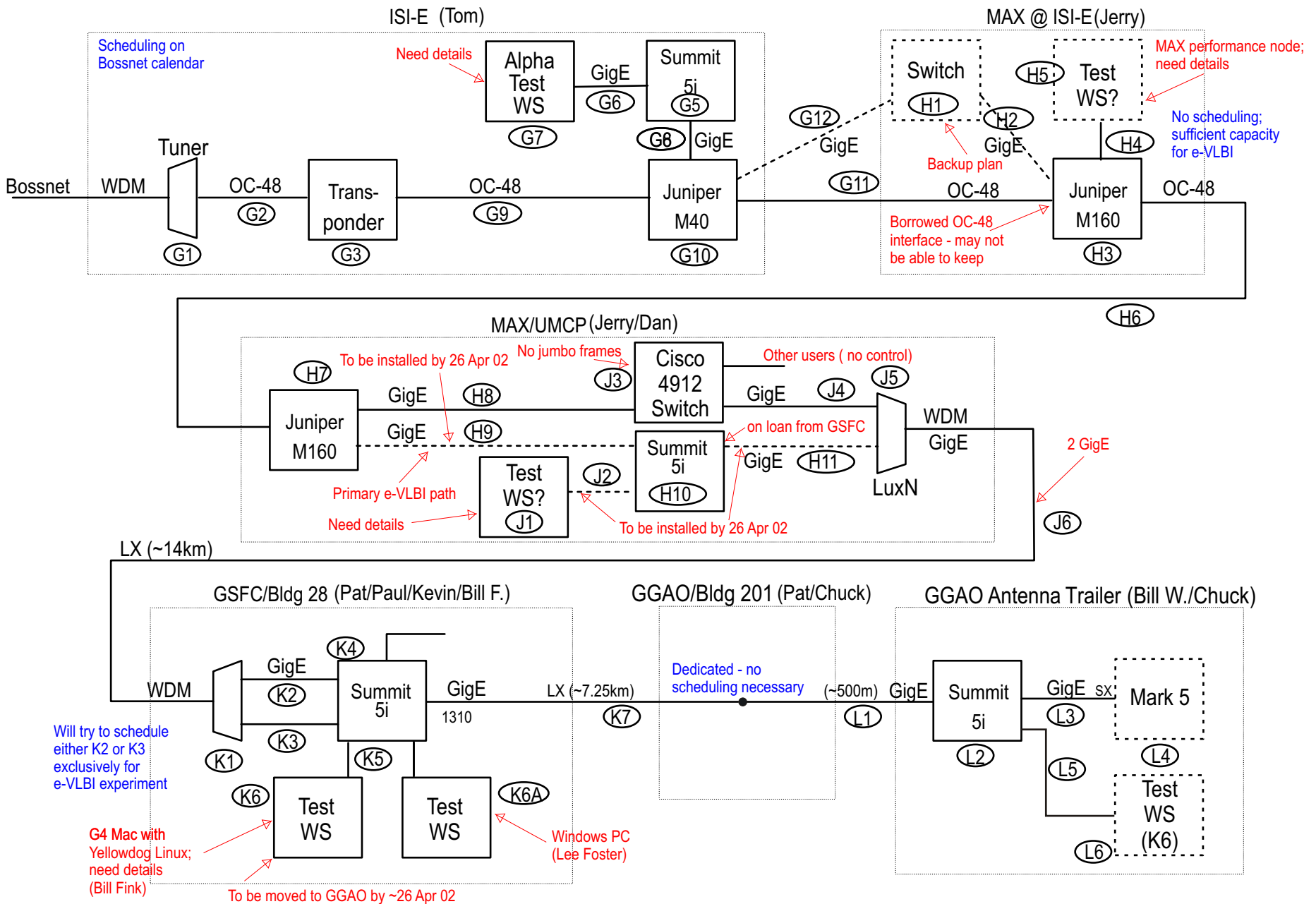

Figure 2: e-VLBI Path - ISI-E to GSFC/GGAO