

**MASSACHUSETTS INSTITUTE OF TECHNOLOGY**

**HAYSTACK OBSERVATORY**

*WESTFORD, MASSACHUSETTS 01886*

*Telephone: 978-692-4764*

*Fax: 781-981-0590*

6 May 2002

TO: Distribution  
FROM: Alan R. Whitney  
SUBJECT: 6 May 2002 e-VLBI telecon summary

Attendees:

Lee Foster, Pat Gary, Chuck Kodak, Paul Lang, Bill Wildes – GSFC

Steve Bernstein – Lincoln Laboratory

Richard Crowley, Kevin Dudevoir, Arthur Niell, Mike Titus, Alan Whitney – Haystack Observatory

This telecon is one of an ongoing series of telecons to prepare for gigabit/sec e-VLBI demonstrations between NASA GSFC and MIT Haystack Observatory using a combination of network facilities including all or part of GlowNet, Bossnet, ISI-E, SuperNet, Max and GSFC/HECN.

Status Reports

The attached figures of the e-VLBI path have been updated to reflect current status and are pretty much self-explanatory; critical status items are indicated in red. In addition, the following comments are relevant:

- Steve reported that the Bossnet OC-48 link is still down. Peter Schultz and Tom Lehman are pursuing, but Tom is away this week, so likely will not be up before next week.
- Tom Lehman has sent a test workstation to LL (labeled E5A in Figure 1)
- Pat reported that links H9 and H11 are now in place, but that the Juniper M160 at H7 is not yet configured to use these links; Pat will work with Jerry Sobieski to get this done. The test workstation at J1 is now in place, but vital characteristics of J1 are not known; Pat will coordinate with Jerry to get this information.
- Pat reported that there has been some difficulty in configuring the kernel for test workstation K6, but hope to complete this effort soon and move K6 to position L6 at GGAO.
- Steve reported that the LL radar is expected back on-line sometime mid-May, at which time the Haystack-LL e-VLBI link will again be shared and will need to be scheduled.

Performance Testing

Kevin and John Ball are working on application software at Haystack; present systems are too slow (~380 Mbps with Mark 5 systems back-to-back with a GigE connection), but are expected to be substantially boosted by use of scatter-gather DMA, which should be available in a few weeks.

Kevin reported that performance testing that he and Tom Lehman have been doing between ISI-E and

LL/Haystack is still show puzzling results. Kevin reported the following numbers:

- Haystack (B3) to/from LL (E5) - ~980 Mbps
- Haystack (B3) to ISI-E (G7) - ~300 Mbps
- ISI-E (G7) to Haystack (B3) - ~550 Mbps
- ISI-E (G7) to LL (E5A) - ~800 Mbps
- LL (E5A) to ISI-E (G7) – not tested

Difficulties with the Bossnet link have prevented further testing at this point. The asymmetry and inconsistent performance numbers are not yet understood. Kevin and Tom are pursuing. Coming to an understanding of these differences is critical to achieving the desired data rates.

### Other

Pat re-iterated that we need to create a summary of the vital characteristics of each of the test workstation. Kevin will create such a list of workstations he knows, along with a summary of performance results, together and distribute.

Pat also re-iterated the importance of a continuing program. Alan outlined the plans for Haystack, LL (Steve Bernstein et al) and MIT (John Wroclawski et al) to collaborate on a proposal to NSF to do exactly this. This includes developing special protocols for e-VLBI to better utilize network facilities, as well as infrastructure building and testing for e-VLBI. There is much interest in connecting to Internet2 and thence to overseas connections such as TransPAC (to Japan) and Surfnet (to Europe). Suggestions are welcome. Paul indicated that Dan Magorian is interested in looking into possibility of providing ‘wavelength service’ across the MAX network, for example.

### Action Items

*Kevin, Tom, Pat:* Gather and distribute workstation configuration information as necessary. Kevin will put together and distribute a list of vital statistics of test workstations and performance-test data to date.

*Steve:* Check on expected date that Grownet connection will once again be shared.

*Steve:* Keep tabs on status of Bossnet and notify group when problem is fixed.

*Pat:* Work with Jerry Sobieski to configure Juniper M160 at H7.

*Pat:* Finish work on test workstation K6, test and move to GGAO (position L6).

### Next telecon

Next telecon will be **Wed, 29 May 2002** at 2 pm.

xc: Steve Bernstein, LL  
Jim Calvin, LL  
Lorraine Prior, LL  
Leslie Weiner, LL  
Herbert Durbeck, GSFC  
Lee Foster, GSFC  
Pat Gary, GSFC  
Chuck Kodak, GSFC  
Kevin Kranacs, GSFC  
Paul Lang, GSFC  
Aruna Muppalla, GSFC  
Bill Wildes, GSFC

Dan Magorian, UMCP  
Tom Lehman, ISI  
Jerry Sobieski, Max  
Richard Crowley, Haystack  
Kevin Dudevoir, Haystack  
Hans Hinteregger, Haystack  
Arthur Niell, Haystack  
Joe Salah, Haystack

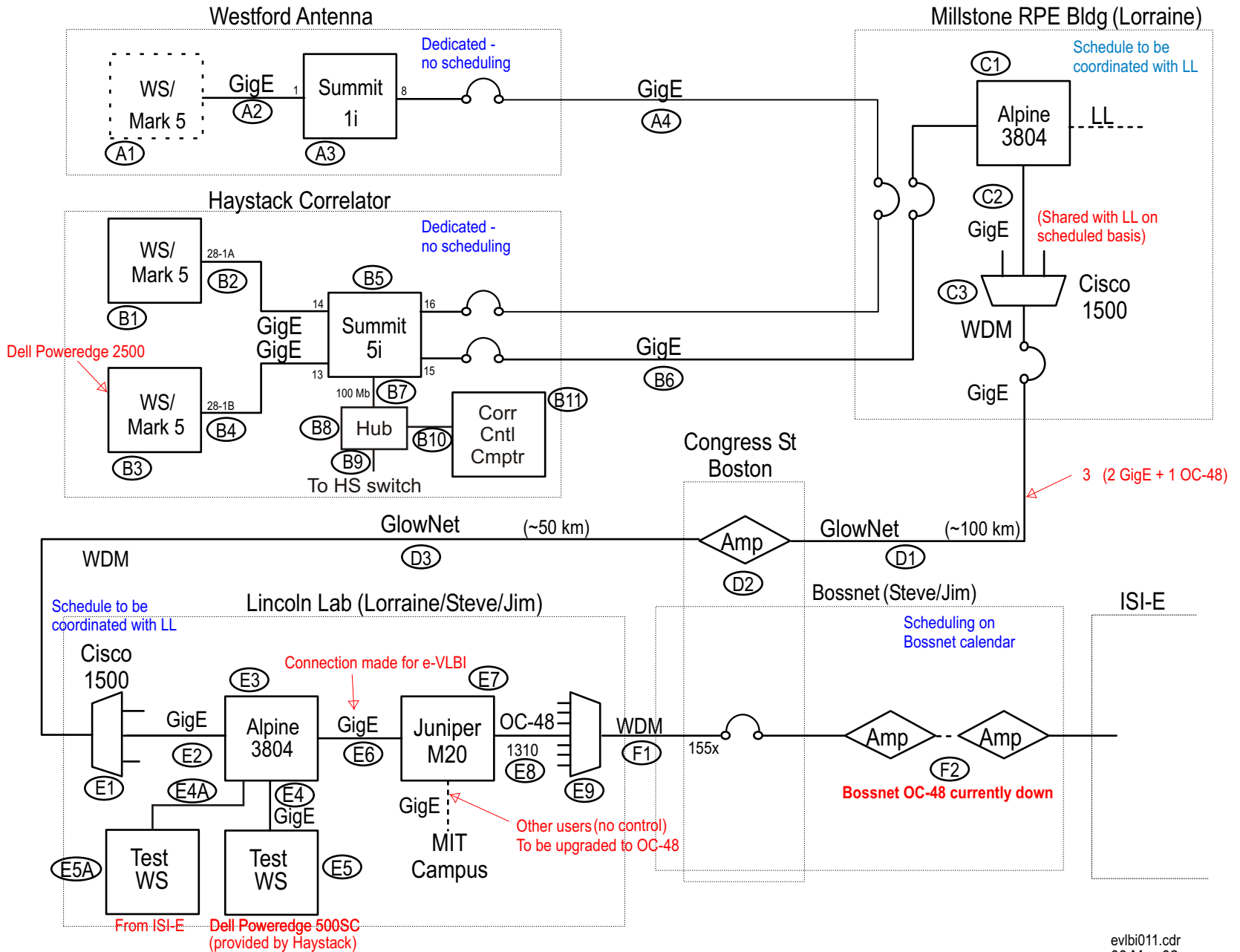

Figure 1: e-VLBI Path - Haystack to ISI-E

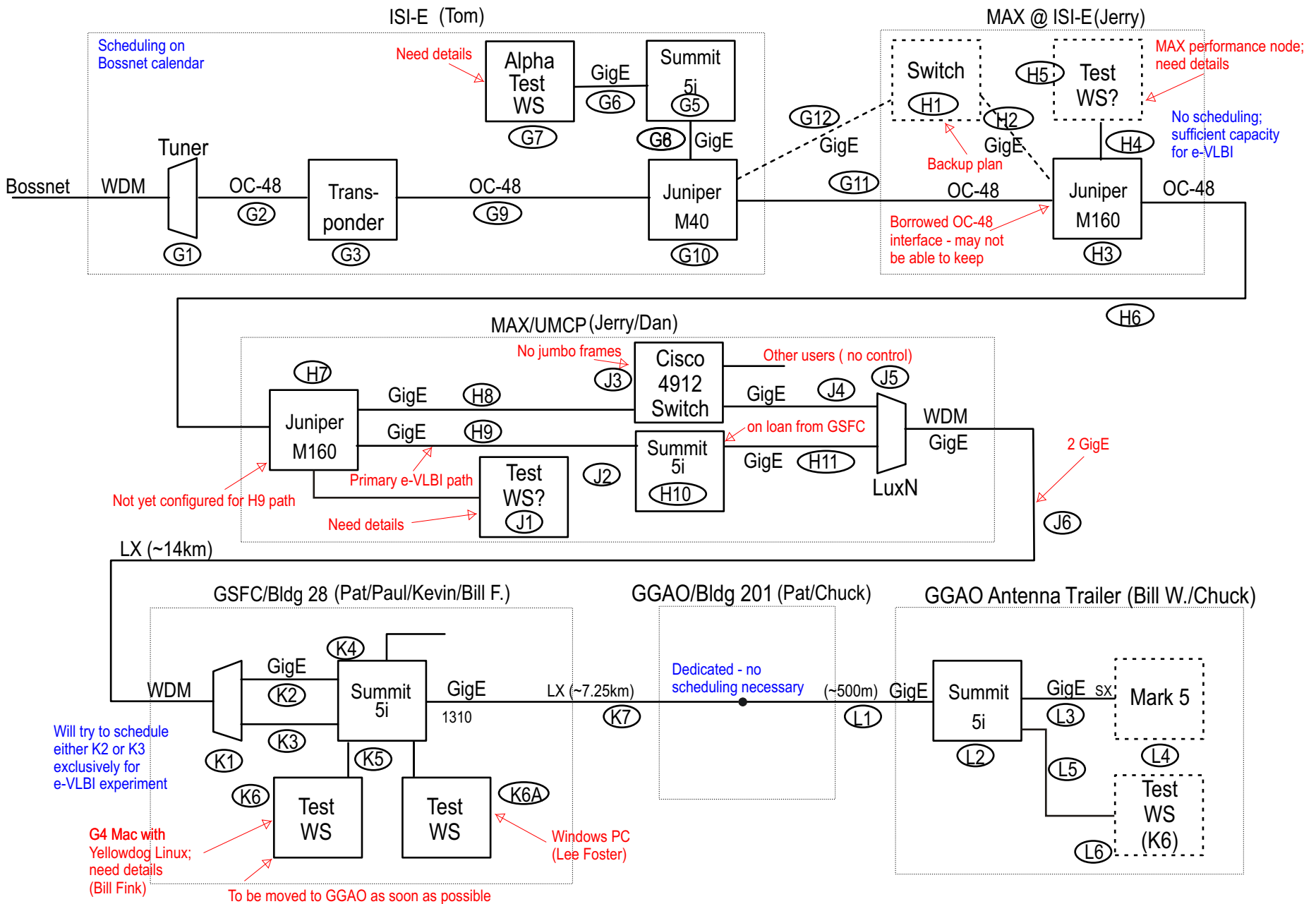

Figure 2: e-VLBI Path - ISI-E to GSFC/GGAO