

**MASSACHUSETTS INSTITUTE OF TECHNOLOGY**

**HAYSTACK OBSERVATORY**

*WESTFORD, MASSACHUSETTS 01886*

*Telephone: 978-692-4764*

*Fax: 781-981-0590*

12 July 2002

TO: Distribution  
FROM: Alan R. Whitney  
SUBJECT: 11 July 2002 e-VLBI telecon summary

Attendees:

Lee Foster, Bill Fink, Pat Gary, Kevin Kranacs, Paul Lang – GSFC

Steve Bernstein, Lorraine Prior, Peter Schultz – Lincoln Laboratory

Tom Lehman – ISI-E

Richard Crowley, Hans Hinteregger, Arthur Niell, Mike Titus, Alan Whitney – Haystack Observatory

This telecon is one of an ongoing series of telecons to prepare for gigabit/sec e-VLBI demonstrations between NASA GSFC and MIT Haystack Observatory using a combination of network facilities including all or part of Glownet, Bossnet, ISI-E, SuperNet, Max and GSFC/HECN.

Status Reports

The attached figures of the e-VLBI path have been updated to reflect current status and are pretty much self-explanatory; critical status items are indicated in red. In addition, the following comments are relevant:

- Peter reported that there is still a problem with the OC-48 Bossnet service and LL is short of personnel to address the problem immediate. As a result, Bossnet will be maintained as a GigE link until at least August. The GigE link seems to be working properly and is suitable for the e-VLBI demonstration; however, the Bossnet GigE link is shared with MIT campus, so Bossnet use for e-VLBI needs to be scheduled (via Bossnet scheduling calendar) so that campus activity can be suspended while e-VLBI testing takes place. The Bossnet problem appears to be somewhere in the path between New York and Newark, but is not yet isolated.
- Router configurations at G10, H3 and H7 have been updated, as promised at the last meeting, for e-VLBI use.
- Test workstation at K6 is now named ‘clifford’ (not ‘dawg’). Alan will update on workstation specification list.
- Lorraine reported that another LL demonstration using Glownet is scheduled for 22 July, during which time Glownet will be unavailable for e-VLBI.
- Haystack target date is tentatively August for full demonstration.

## Performance Testing

Bill F. requested that all test workstations install a nuttcp server to facilitate ease of testing. He will distribute a note to everyone with details of the installation procedure (has been done).

Kevin D. conducted several short tests from Haystack ('evlibhay') to GSFC/GGAO ('pluto'), achieving ~350 Mbps throughput. Below is a summary of his results:

Configuration MIT(evlibhay):

```
ip          140.173.174.4
mtu         4470 (9000 max)
mss         4418
/proc/sys/net/core/wmem_max    8388608
/proc/sys/net/core/rmem_max    8388608
/proc/sys/net/ipv4/tcp_timestamps 1
/proc/sys/net/ipv4/tcp_sack    1
/proc/sys/net/ipv4/tcp_wmem    "4096 1048576 8388608"
/proc/sys/net/ipv4/tcp_rmem    "4096 1048576 8388608"
nuttcp     v3.1.9
```

Configuration GGAO(pluto):

```
ip          206.196.178.53
nuttcp     v3.2.1
Rtt:       ~ 15 msec
Throughput: ~ 350 Mb/s (Haystack to GGAO)
```

Note: Only very short duration (1-15 secs) tests were done.

The following was typical output:

```
[kad@evlibhay bin]$ ./nuttcp -t -l4418 -n16384 -w2048 -ws2048 206.196.178.53
nuttcp-t: v3.1.9: socket
nuttcp-t: buflen=4418, nbuf=16384, nstream=1, port=5001 tcp -> 206.196.178.53
nuttcp-t: connect to 206.196.178.53
nuttcp-t: send window size = 4194304, receive window size = 1048576
nuttcp-t: 69.031 MB in 1.64 real seconds = 43007.87 KB/sec = 352.3205 Mb/s
nuttcp-t: 16384 I/O calls, msec/call = 0.10, calls/sec = 9968.33
nuttcp-t: 0.0user 0.3sys 0.01real 21% 0i+0d 0maxrss 0+0pf 0+0csw
```

```
nuttcp-r: v3.2.1: socket
nuttcp-r: buflen=4418, nbuf=16384, nstream=1, port=5001 tcp
nuttcp-r: accept from 140.173.174.4
nuttcp-r: send window size = 16384, receive window size = 2097152
nuttcp-r: 69.031 MB in 1.68 real seconds = 41996.25 KB/sec = 344.0333 Mb/s
nuttcp-r: 69.031 MB in 0.22 CPU seconds = 321309.09 KB/cpu sec
nuttcp-r: 16467 I/O calls, msec/call = 0.10, calls/sec = 9783.16
nuttcp-r: 0.0user 0.2sys 0:01real 13% 0i+0d 0maxrss 1+1pf 0+0csw
```

Kevin D. feels that there may some tuning issues on 'pluto', but he was unable to get a password to make tuning changes. Bill F. will work with Kevin on 'pluto' tuning issues. Tom also suggested trying a multi-stream TCP process to improve aggregate throughput rate (easily done with nuttcp).

nuttcp is not yet ported to Windows. Lee reports that a summer student is currently working on this project.

Tom will investigate possibility of putting nuttcp on MAX test workstations, but warned that these machines are not particularly high-performance machines so probably may not be able to draw useful performance conclusions.

Tom and Bill will coordinate increasing mtu size on paths between ISI-E and MAX. The issue is complicated by the use of 'frame relay encapsulation' on some of these links and links to Abilene.

#### Action Items

*Bill F.*: Distribute information on nuttcp routine (has been done).

*Tom/Bill F.*: Will coordinate installation of nuttcp on ISI-E test machines (Tom will be on vacation for next two weeks, but will be available via e-mail occasionally during this time). Bill will then do testing on ISI-E/GSFC link and report to group.

*Tom/Bill F.*: Will coordinate mtu change on ISI-E/MAX links.

*Tom*: Will investigate possibility of putting nuttcp on MAX test workstations.

*Kevin D./Bill F.*: Will coordinate to allow Kevin access to 'pluto' (requires Kerberos account).

#### Next telecon

Next telecon will be **Wed, 7 Aug 2002** at 2 pm.

xc: Steve Bernstein, LL  
Jim Calvin, LL  
Lorraine Prior, LL  
Leslie Weiner, LL  
Herbert Durbeck, GSFC  
Lee Foster, GSFC  
Pat Gary, GSFC  
Chuck Kodak, GSFC  
Kevin Kranacs, GSFC  
Paul Lang, GSFC  
Aruna Muppalla, GSFC  
Bill Wildes, GSFC  
Dan Magorian, UMCP  
Tom Lehman, ISI  
Jerry Sobieski, Max  
Richard Crowley, Haystack  
Kevin Dudevoir, Haystack  
Hans Hinteregger, Haystack  
Arthur Niell, Haystack  
Joe Salah, Haystack

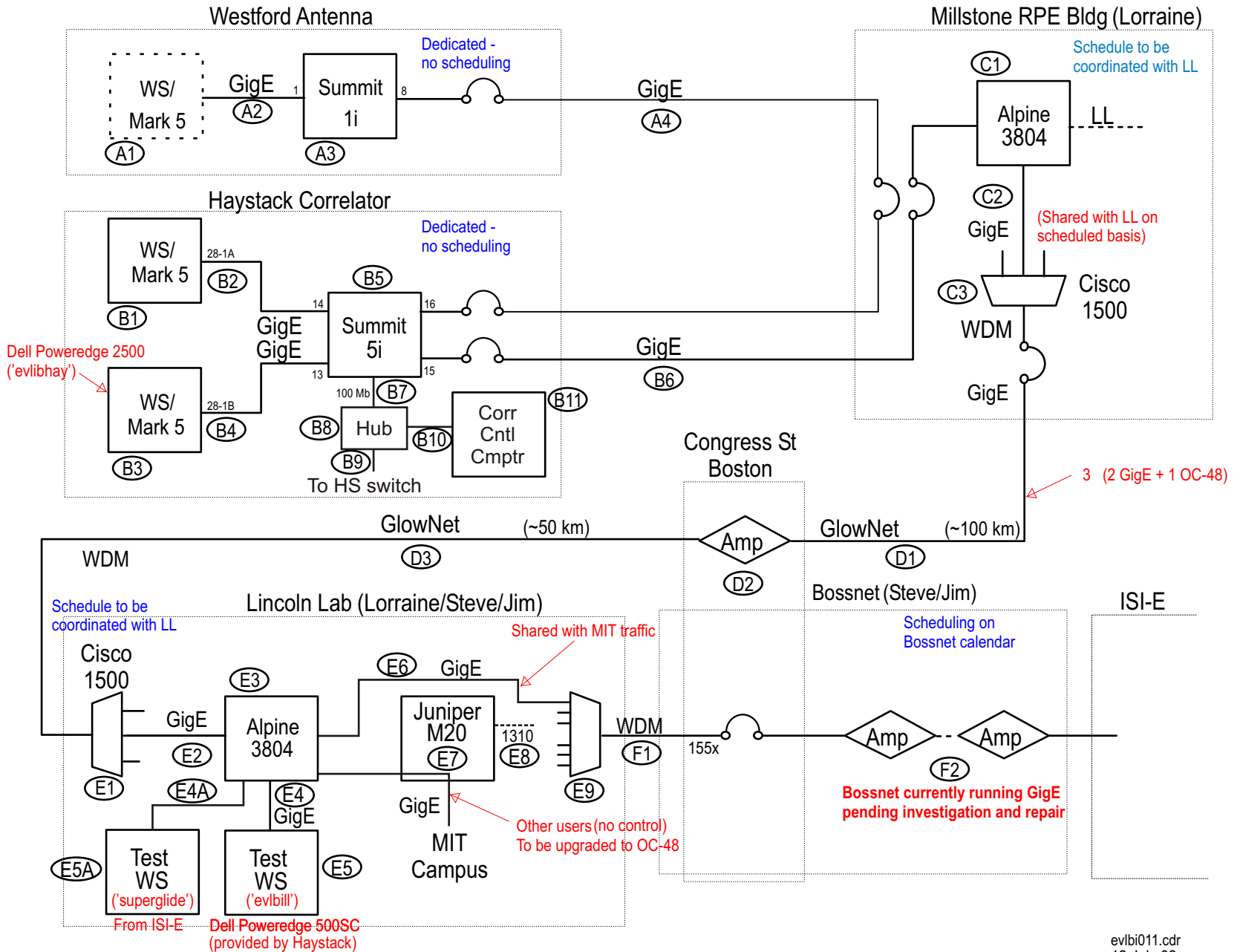

Figure 1: e-VLBI Path - Haystack to ISI-E

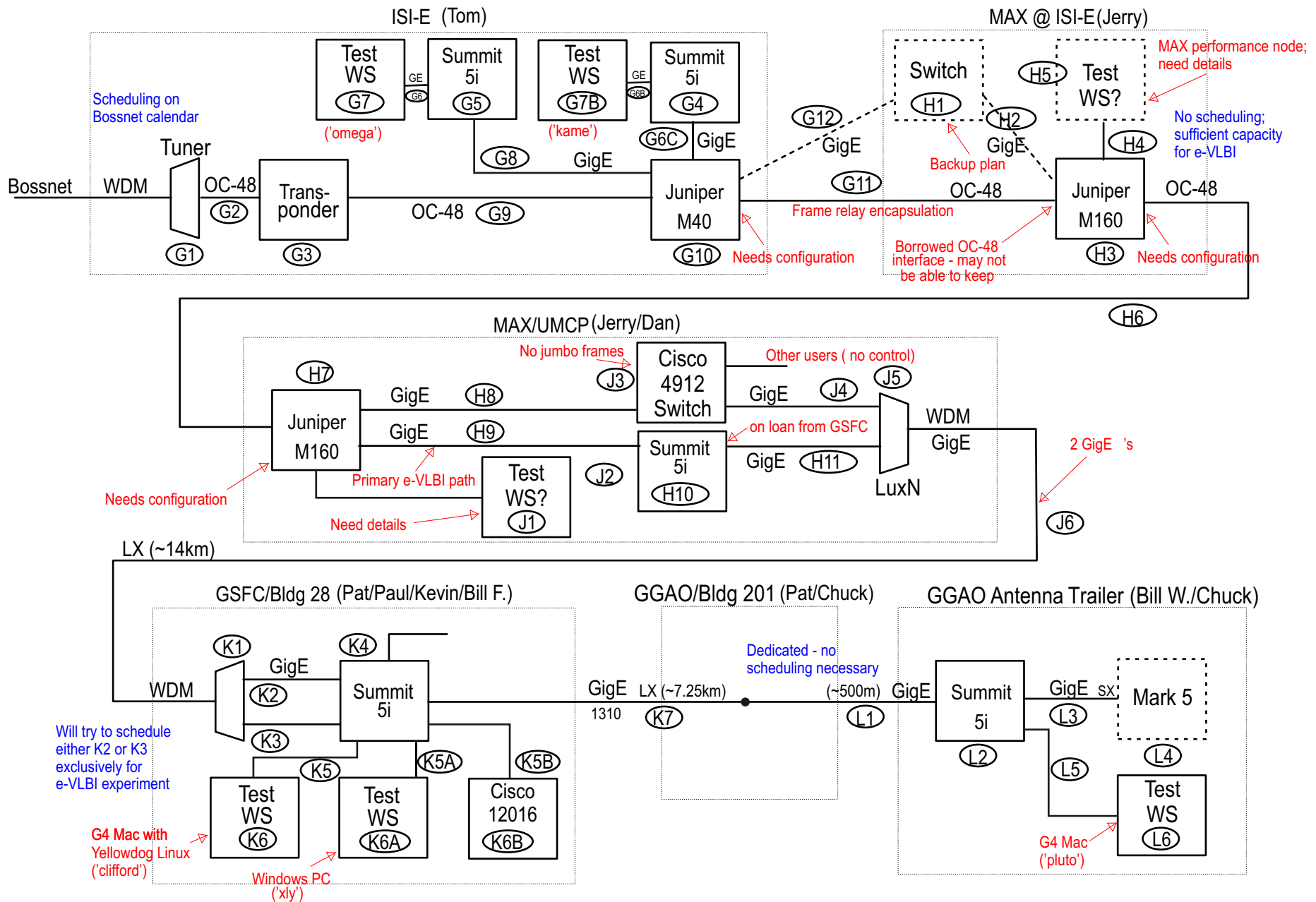

Figure 2: e-VLBI Path - ISI-E to GSFC/GGAO