

MASSACHUSETTS INSTITUTE OF TECHNOLOGY

HAYSTACK OBSERVATORY

WESTFORD, MASSACHUSETTS 01886

Telephone: 978-692-4764

Fax: 781-981-0590

28 August 2002

TO: Distribution
FROM: Alan R. Whitney
SUBJECT: 26 August 2002 e-VLBI telecon summary

Attendees:

Lee Foster, Pat Gary, Chuck Kodak, Kevin Kranacs, Paul Lang, Bill Wildes – GSFC

Steve Bernstein, Lorraine Prior, Peter Schultz – Lincoln Laboratory

Tom Lehman – ISI-E

Richard Crowley, Kevin Dudevoir, Hans Hinteregger, Arthur Niell, Mike Titus, Alan Whitney – Haystack Observatory

This telecon is one of an ongoing series of telecons to prepare for gigabit/sec e-VLBI demonstrations between NASA GSFC and MIT Haystack Observatory using a combination of network facilities including all or part of GlowNet, Bossnet, ISI-E, SuperNet, Max and GSFC/HECN.

ACTION ITEMS ARE HIGHLIGHTED IN RED.

Status Reports

The attached figures of the e-VLBI path have been updated to reflect current status and are pretty much self-explanatory; critical status items are indicated in red. In addition, the following comments are relevant:

- Peter reported LL sent technicians to NYC area to isolate Bossnet problems, one problem each in northbound and southbound paths. The problems have been located as a 10dB loss in a Quest rack; coordination with Quest is in progress to fix the problems, hopefully within next 2 weeks. **Peter will keep group informed.**
- Peter reported that Tom is planning to send 10GigE equipment up to LL and may also visit. Experiments on Bossnet will have to wait for 1) fix of Bossnet problem and 2) new high-quality fiber from ISI to Eckington to support 10GigE.
- Kevin D. reported he was unable to connect to the Juniper router at LL or ping anything downstream from Haystack. **Lorraine will investigate.**
- Paul reported that MAX is still looking into problem in direct connection from UMCP to ISI-E that was reported at the last telecon; traffic in UMCP to ISI-E is still routed through Eckington around the ring.
- **Alan will e-mail Bill Fink to get information on test workstation at UMCP** (J1 on connection diagram); this information will be added to test workstation database.

- After some initial difficulty, Kevin D. has done testing with copper (RJ-45) GigE NIC's. Testing between a dedicated workstation (B3) and a Mark 5 at Haystack, connected through a Summit 5i switch (B5), sustained ~980 Mbps over several hours using nttcp. The Mark 5 unit will be shipped to GGAO within next day or so. A second Mark 5 unit will be sent to GGAO within next week or so.
- Alan reported that two Mark 5's will be in place at Westford within next couple of days.
- Pat summarized the Joint Engineering Team (JET) meeting between Internet2/Abilene (university funded) and FedNets (federally funded, including, DREN, NREN, ESNET [DOE], among others). At one of recent meetings, Tom summarized the e-VLBI testing work done by our team. Two interesting follow-ups:
 1. About ten years ago the first Gbps (HIPPI-based) testbeds were set up along West Coast; achieving data rates ~700 Mbps. Though the recent demonstrations by our team are only marginally higher in data rate, the (incremental) cost of our Gbps link is probably well less than 1% of the cost ten years ago!
 2. At one of the JET meetings, Guy Almes, director of engineering for Abilene, (works for Steve Corbato, directory of Abilene, <corbato@internet2.edu>), expressed interest in e-VLBI, particularly the potential international connections, and is interested in trying to help e-VLBI. As such, Guy is a potentially valuable contact. **Alan will contact Guy (<alme@internet2.edu>).**
- **Kevin still has an action item to write up the results of his Haystack/GGAO tests.**
- The suggestion has been made that a joint project document be created for this e-VLBI project. **Alan volunteered to create an outline for such a document, to be filled in by key people on the team.**
- GGAO data IP address for first Mark 5 will be 206.196.178.54. Gateway address is 206.196.178.49.
- **Tom will distribute available information about 10GigE equipment.**
- In response to a question from Hans regarding aggregating multiple GigE flows into a single high-speed stream, Paul mentioned that Cisco, Extreme and Summit all support such arrangements – Cisco calls it 'EtherChannel', 'Extreme' calls it 'Sharing', 'Summit' calls it 'Bonding'. **Paul will distribute short e-mail with references.**

Action Items Carried Forward

Alan: Find date of e-VLBI meeting in Europe in spring 2003.

Alan: Organize face-to-face U.S. e-VLBI meeting to precede European spring 2003 meeting.

Alan: Distribute slides on e-VLBI to group (done).

Next telecon

Next telecon will be **Mon, 16 Sep 2002** at 2 pm EDT.

xc: Steve Bernstein, LL
Jim Calvin, LL
Lorraine Prior, LL
Leslie Weiner, LL
Herbert Durbeck, GSFC
Lee Foster, GSFC
Pat Gary, GSFC
Chuck Kodak, GSFC
Kevin Kranacs, GSFC
Paul Lang, GSFC
Aruna Muppalla, GSFC
Bill Wildes, GSFC
Dan Magorian, UMCP
Tom Lehman, ISI
Jerry Sobieski, Max
Richard Crowley, Haystack
Kevin Dudevoir, Haystack
Hans Hinteregger, Haystack
Arthur Niell, Haystack
Joe Salah, Haystack

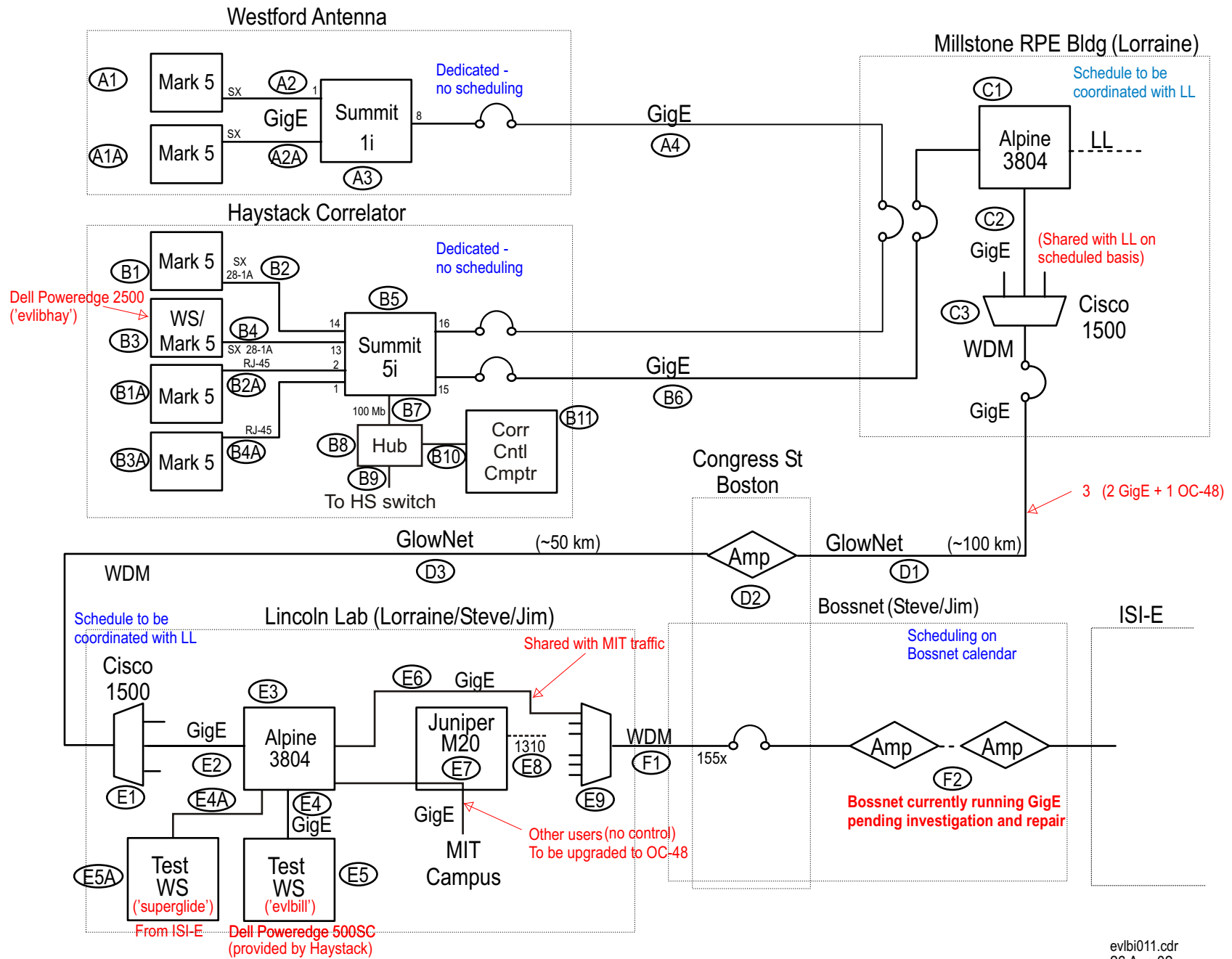

evlbi011.cdr
26 Aug 02

Figure 1: e-VLBI Path - Haystack to ISI-E

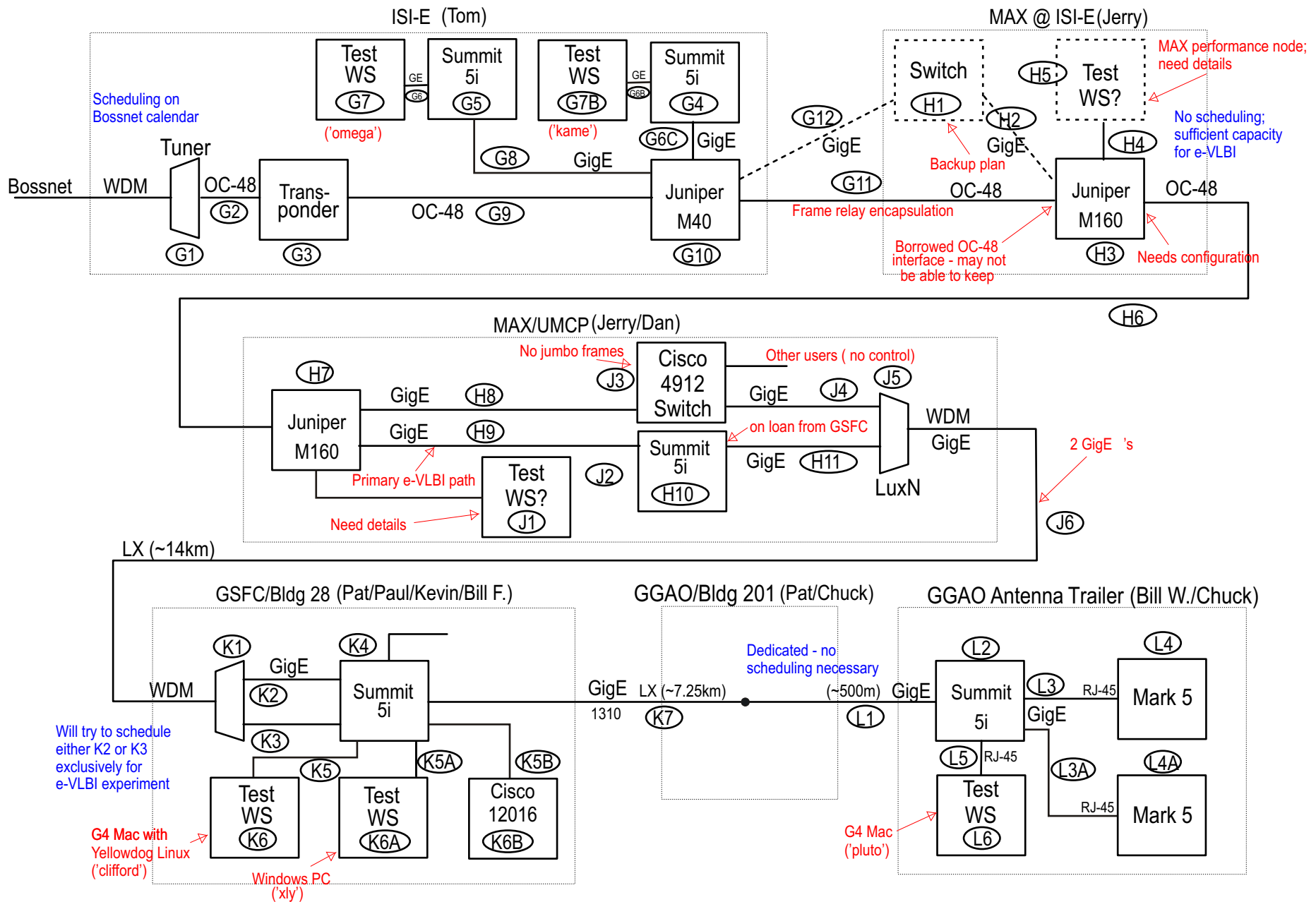

Figure 2: e-VLBI Path - ISI-E to GSFC/GGAO