

# Mark 5A Disk-Module Assembly, Test and Conditioning

Alan R. Whitney  
MIT Haystack Observatory  
11 Nov 2005

Attached to this memo are instructions from Conduant on how to assemble '8-pack' disk modules. Please follow them carefully. Please read this introductory material for further information and tips on module assembly.

## 1. Disk Module Configuration

Each '8-pack' module holds up to 8 disks, consisting of 4 Master/Slave pairs. The following applies to the '8-pack' modules.

1. All disks within a module should be of the same capacity; if disks are not of the same capacity, the effective capacity of the module becomes (number of disks)\*(capacity of the smallest disk).
2. All disks must be configured for 'Cable Select' by properly positioning the jumpers on the disk drives.
3. From front-to-back of the module, the disk positions are 0M, 0S, 1M, 1S, 2M, 2S, 3M, 3S.
4. If fewer than 8 disks are installed, the data-rate capability is correspondingly reduced; the allowed number of disks is 1, 2, 3, 4, 6 or 8. Disk positions and module capacity for these various numbers of disks are given in Table 1; please also see Appendix A in the Mark 5A User's Manual for additional information on disk requirements and disk recording times.

#disks	Positions	Max data rate (Mbps)
1	0M	128
2	0M, 1M	256
3	0M, 1M, 2M	256
4	0M, 1M, 2M, 3M	512
6	0M, 0S, 1M, 1S, 2M, 2S	512
8	All	1024

Table 1: Position and max data rate for various numbers of disks

5. It is recommended that all disks in a module be of the same vendor and model. However, if this is not possible, all disks must be of the same vendor.

When the Mark 5A is being used in 'bank mode' (that is, each module bank is being used independently), there are no restrictions concerning the mixing of modules so long as the individual modules each adhere to the stated rules above.

When the Mark 5A is being used in 'non-bank mode' ('Mark 5P' mode), the mounted disks act as a single 'module' of up to 16 disks, with the disk positions becoming 0M, 0S, ... 3M, 3S in Bank A and 4M, 4S, ... 7M, 7S in Bank B. The rules for this mode can be directly extrapolated from the rules stated for a single '8-pack' module, however, the maximum data rate remains 1024 Mbps.

## 2. Module Assembly Tips

In addition to the instructions provided by Conduant, we suggest the following procedures be observed during module assembly:

1. **Before disassembling an empty module in preparation for installing disks, make sure the 200-pin connector fully mates with the mating connector on the chassis backplane.** There is some play in the position of the module backplane when the holddown screws are loosened. Normally there is no need to remove the module backplane. However, if the backplane is removed, be very careful to restore proper alignment with the chassis backplane connector when it is re-assembled. **For proper alignment the circuit board must be in the lowest position before tightening any of the screws.**
2. Make sure that all disks are properly configured for 'Cable Select' mode.
3. When plugging the disks into the backplane connectors, make absolutely sure that they are properly registered into the backplane connectors. It is sometimes possible for the connectors to be mis-registered by a pin spacing, in which case they obviously will not work. The backplane connector for disk 0 is somewhat cantilevered and may slightly bend the backplane during insertion; make sure the disk connector is fully seated. **Use Loctite solution** on all disk-mounting screws.
4. **Make sure that the module is assembled so that the two bottom slides are exactly parallel.** This is best accomplished by assembling the two module halves on a flat surface. Once all screws are tightened, and before the front panel is installed, the module should lie flat on with no wobbling.
5. There is a bit is play in the width of the module, so don't tighten front and rear sets of screws until you have done a test fit of the module for smooth insertion and adjusted the width to slide smoothly. **Test for smooth insertion and proper connector mating before the front panel is installed.**
6. See Sections 8 and 9 regarding ejector retainer clip and clamp connector installation.

## 3. Testing the Module Backplane

Conduant ships new modules with untested backplanes. This is done in order to keep the price of the module down since testing the backplane is very labor intensive. Therefore, it is possible that you may encounter a bad backplane. If you have assembled a new module with new disks and the newly assembled module does not work, it can be difficult to determine where the problem is. Though it is quite a bit more work, we suggest the following when assembling new modules:

1. Empty a known good module of its 8 disks (hopefully with no data you want to keep).
2. Test each new module with these known-good disks before assembling them with new disks. With a little experimentation, you will find you can do this test fairly quickly with a partially assembled module. After the module is inserted into the Mark 5A, run 'ssopen' to power-up and initialize the module; if ssopen is successful and 8 disks are found, chances are very high that the new module backplane is OK; run 'SSReset' to power down. If 'ssopen' hangs for any reason and you are unable to power-down the module, it is recommended that you power down the Mark 5A system and re-boot.

#### 4. Quick-Test and Initialization of a New Module

Once a new module is assembled with new disks and passes the ‘ssopen’ test, do a quick functionality test and initialization using the *Mark5A* program on a known working Mark 5A system. Proceed as follows (see the ‘Mark 5A Users Manual’<sup>1</sup> for more details on the *Mark5A* program):

1. Insert module into Bank A and lock with keylock (‘Locked’ LED will lite).
2. Run ‘*ssopen*’. If *ssopen* is successful and 8 disks are found, chances are pretty good everything is OK. If not, proceed to ‘Diagnosing Problems’.
3. Start *Mark5A* program with ‘*Mark5A -m 0 -f 1 &*’ (‘*Mark5A 0 0 &*’ if version 2.3 or earlier) . You should observe the following:
  - a. Status LED’s above module will flash briefly.
  - b. ‘Power’ LED will come on and stay on.
  - c. The ‘disk activity’ LED’s on the module corresponding to installed disks will lite, then extinguish one by one from top to bottom. An LED that fails to extinguish during this sequence usually indicates a problem with the corresponding master/slave pair of disks.
  - d. The status LED’s ‘Ready’ and ‘Selected’ will lite.
  - e. The ‘disk activity’ LED’s will flash sequentially from top to bottom.
4. Start the interactive operator interface by entering ‘*tstMark5A*’.
5. **If a Mark 4 formatter is available**, connect it to the Mark 5A input and set it to output 64 tracks at 16 Mbps/trk (see ‘Mark 5A System Test Procedures’<sup>2</sup> Appendix B for details on formatter configuration). On the Mark 5A, execute the following commands (see ‘Mark 5A Command Set’<sup>3</sup> for details of commands and responses):

<i>disk_serial?;</i>	Read the disk serial #'s (make sure all are there!)
<i>reset=erase;</i>	Initialize and erase the module
<i>mode=mark4:32;</i>	Set to 64-track mode (512 Mbps)
<i>start_stats;</i>	Clear disk-performance statistics counters
<i>record=on:test;</i>	Start recording ( <b>record for a couple of minutes, at least</b> )
<i>record=off;</i>	Turn off recording
<i>get_stats?;</i>	Check the disk-performance statistics ( <b>repeat once for each disk in module</b> ); check for ‘slow’ disks
<i>scan_check?;</i>	Check the disk data
<i>play_rate=clock:18;</i>	Set track-playback clock rate to 18Mbps/trk
<i>start_stats;</i>	Clear disk-performance statistics counters
<i>scan_play;</i>	Playback the scan (will stop automatically at end)

---

<sup>1</sup> ‘Mark 5A User’s Manual’ available at Mark 5 web site (<http://web.haystack.mit.edu/mark5/Mark5.htm>).

<sup>2</sup> ‘Mark 5A System Test Procedures’ available at Mark 5 web site (<http://web.haystack.mit.edu/mark5/Mark5.htm>).

<sup>3</sup> ‘Mark 5A Command Set’ available at Mark 5 web site (<http://web.haystack.mit.edu/mark5/Mark5.htm>). Make sure your version of the *Mark5A* program matches the revision level of the command set documentation.

- |                     |  |
|---------------------|--|
| <i>get_stats?;</i>  | Check disk statistics ( <b>repeat once for each disk in module</b> ) |
| <i>reset=erase;</i> | Erase disk module  |
6. **If a Mark 4 formatter is not available** for testing the module, it may be tested with the internal test-vector generator (tvgr), as follows:
- |                           |   |
|---------------------------|---|
| <i>disk_serial?;</i>      | Read the disk serial #'s (make sure all are there!)   |
| <i>reset=erase;</i>       | Initialize and erase the module   |
| <i>mode=tvgr;</i>         | Set to tvgr mode  |
| <i>play_rate=clock:16</i> | Set tvgr clock rate to 16 MHz (512 Mbps total rate)   |
| <i>start_stats;</i>       | Clear disk-performance statistics counters  |
| <i>record=on:test;</i>    | Start recording ( <b>record for a couple of minutes, at least</b> )   |
| <i>record=off;</i>        | Turn off recording  |
| <i>get_stats?;</i>        | Check the disk-performance statistics<br>( <b>repeat once for each disk in module</b> );<br>there should be no 'slow' disks |
| <i>scan_check?;</i>       | Check the disk data; should show 'tvgr' data  |
| <i>start_stats;</i>       | Clear disk-performance statistics counters  |
| <i>scan_play;</i>         | Playback the scan (will stop automatically at end)  |
| <i>get_stats?;</i>        | Check disk statistics ( <b>repeat once for each disk in module</b> )  |
| <i>reset=erase;</i>       | Erase disk module   |

## 5. Writing a VSN to the Module

Follow these steps to write a permanent Volume Serial Number (VSN) to the module:

1. Assign an 8-character VSN according to the rules in the memo "Mark 5A Disk-Module Labeling and Management Procedures" (available at <http://web.haystack.mit.edu/mark5/operations.html>).
2. With the module inserted into the Mark 5A unit, make sure the module is Ready and Selected. Using the *Mark5A* program, issue the following commands:

<i>VSN=&lt;VSN&gt;;</i>	Write VSN onto permanent area of the module; (example: 'MPI-0153')
<i>VSN?;</i>	Verify VSN and view 'extended-VSN' (example: 'MPI-0153/960/1024' where the module capacity of 960GB and maximum data rate of 1024Mbps have been calculated and assigned by the <i>Mark5A</i> program.
3. Apply printed labels according to the memo "Mark 5A Disk-Module Labeling and Management Procedures" (available at <http://web.haystack.mit.edu/mark5/operations.html>).

The electronically written VSN is permanent in the sense that it will survive both erasure and conditioning of the module. **Important:** The VSN must be written to the module before it is used to record data, otherwise the correlator will not receive the module identification for correlation.

## 6. Module Conditioning

New disks fresh from a manufacturer have generally *not* been fully tested over the complete magnetic surfaces of the disk. A reserve pool of spare sectors is maintained to replace bad sectors, but bad sectors are generally not yet identified.

The stand-alone SSErase program has been augmented to do disk conditioning. With no command-line arguments, SSErase does a simple whole-module erase. There are two settable parameters: -m sets the msglev (range -1 to 3, default 1), and -c sets conditioning (0 for FALSE, 1 TRUE, default FALSE). So, for example:

```
SSErase -m 0 -c 1 &
```

goes through the long conditioning process on whatever disks it can access, up to 16 at a time with modules in both banks. With msglev set to 0, debug prints about every minute to show what's happening. Disk-performance statistics are also gathered during conditioning; they should be examined for any disks that stand out from the norm. However, a suspect disk should always be retested because disks might actually be improved by the conditioning process---that's the point of doing it.

*Conditioning disks at a station is recommended before recording especially if they are to be recorded at or near their maximum data rate, even if the disks have been used successfully before.* Conditioning amounts to a write-read-write cycle through the whole set of disks. Printed with the debugging information and two countdown cycles (one for write and one for read) is the number of bytes *per bus*. With an 8-disk pack, for example, this count starts at a quarter of the total capacity, which is twice the capacity of a single disk. Conditioning one 120-Gbyte disk takes about 101 minutes; two 120-Gbyte disks (as two masters), 103 minutes; four 120-Gbyte disks (as four masters), 111 minutes; eight 120-Gbyte disks (an eight pack), 157 minutes; and sixteen 120-Gbyte disks (two eight packs), 278 minutes. 200-Gbyte disks take about 5/3rds as long---no surprise. Conditioning one 200-Gbyte disk takes about 160 minutes; eight 200-Gbyte disks, 286 minutes; and sixteen 200-Gbyte disks, 465 minutes. These times are approximate for the ideal case, but, if any of the disks has a problem, times can be much longer.

Note 1: **Important:** *If two disk packs are conditioned simultaneously, or anytime you change the configuration of disks in a pack, each disk pack must subsequently be erased separately before recording using a 'reset=erase' command to Mark5A; if this is not done, recording will fail. SSErase may also be used (with no arguments) to erase a pack in Bank A.*

Note 2: *Conditioning does not affect the VSN; it should not have to be rewritten after conditioning.*

## 7. Diagnosing Problems

If a new module fails to operate properly, we suggest the following:

1. Remove all slave disks (2<sup>nd</sup>, 4<sup>th</sup>, 6<sup>th</sup>, 8<sup>th</sup> from front) so that you have only master disks and try again.
2. If this fails, remove master disks (starting from the rear of the module) and try again.
3. If all the above fail, then the module needs repair. You can try to diagnose the problem yourself with the aid of module-backplane schematics which will be provide by Haystack

Observatory on request, or you can return the backplane to Conduant for repair/replacement.

### 8. Note on 200-pin Connectors

Pins 152 and 200 of the 200-pin connector on the module backplane are intentionally recessed for mate sequencing purposes and do not indicate a damaged connector.

### 9. Ejector Retainer Clip Installation

Some modules have been found with an incorrectly installed ejector retainer clip, which may interfere with the module properly seating into the chassis. See Figure 1 for proper installation.

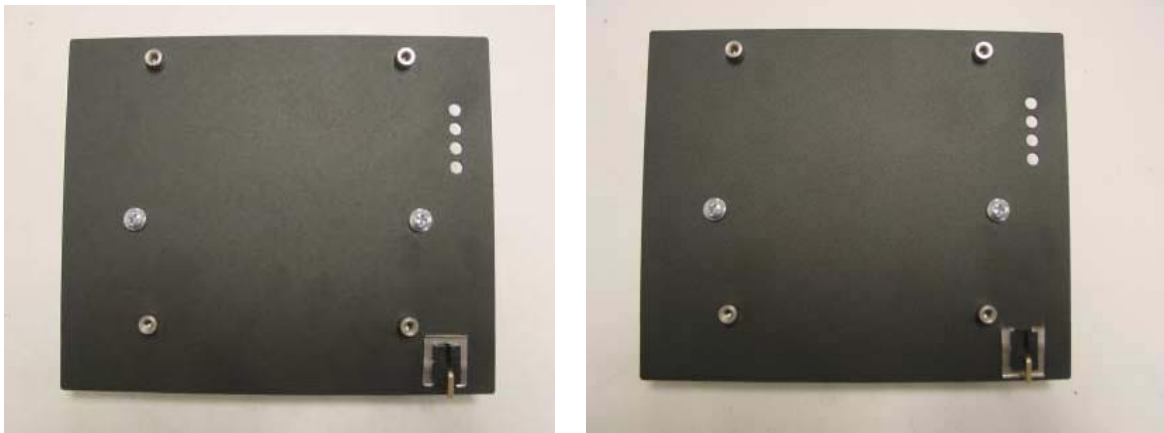

Figure 1: a) Correct orientation of ejector retainer clip on back of front panel  
b) Incorrect orientation of ejector retainer clip; orientation of folded edge will interfere with front face of chassis and prevent full seating of module.

### 10. Connector Clamp Installation

An aluminum clamp has been designed to fit over the 200-pin connector on the module backplane to prevent flexing of the connector and to relieve stress on the solder joints (see Figure 2). Earlier modules did not have this clamp installed when purchased; these modules will be retrofitted with clamps when they are returned to a correlator<sup>4</sup>. Later modules have these clamps installed when purchased.

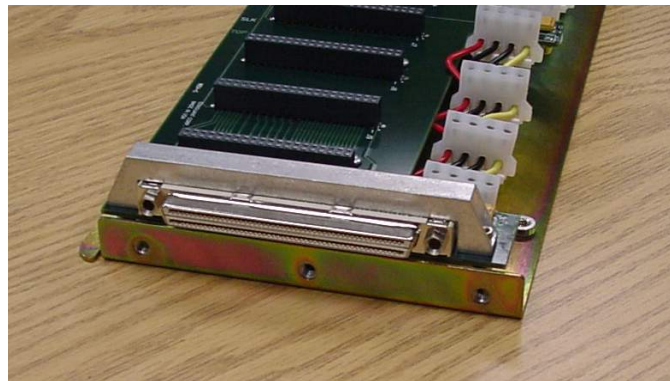

Figure 2: Connector clamp installed over 200-pin module backplane connector

---

<sup>4</sup> These clamps can be installed without disassembling a module with the use of hex-head bolts and a ball-hex driver tool.

# TK-200 8 Pack Drive Module

## Assembly Instructions

Conduant Corporation

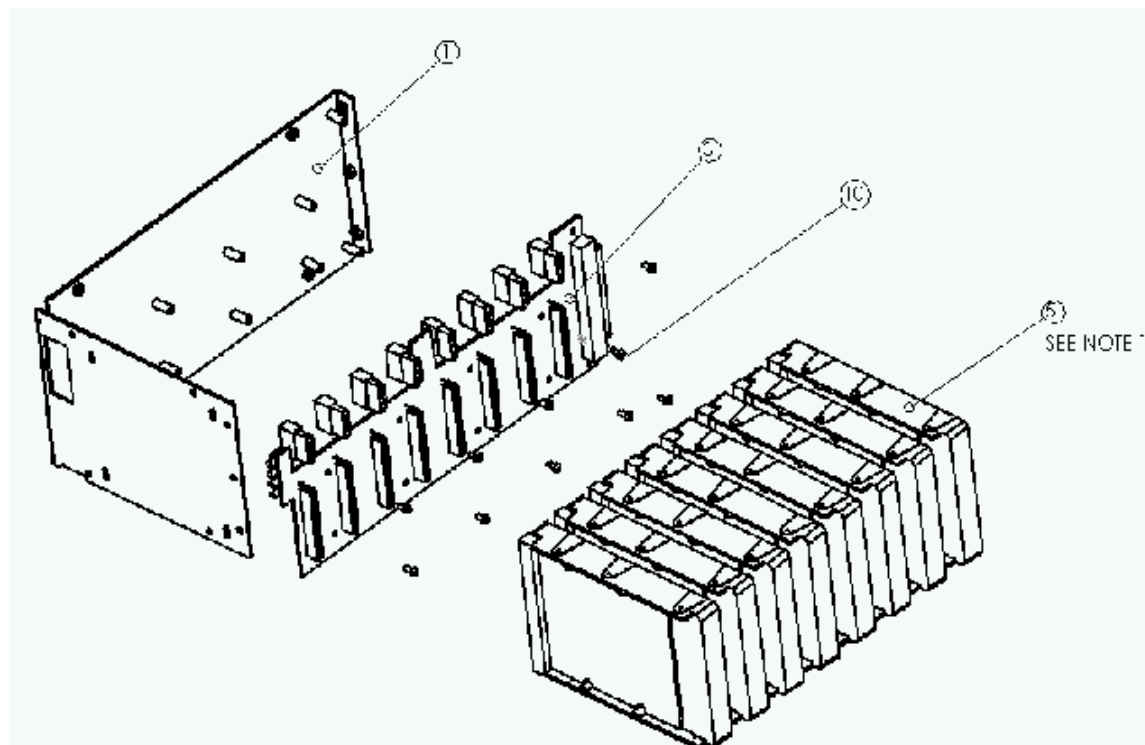

- 1) Secure the drive module circuit board (item 10 above) to the front assembly using ten 4-40x1/4" pan head screws **with Loctite solution**. For proper alignment ensure that the circuit board is in the lowest position before tightening any of the screws.
- 2) To the drive module front assembly plug 8 drives into each of the 40 pin connectors. Use a flathead screwdriver to carefully insert the power cable connectors into each disk drive. Wires between the power connectors should be flexed up or down for proper positioning.
- 3) Using 8-32x1/4" screws (included), secure the drive module rear together to form a rectangular box.
- 4) Using 6-32x1/4" screws (included), loosely secure four drive support brackets to the front and rear of the drive module into the slotted holes. Do not completely tighten the screws to allow for final alignment.  
NOTE: Make sure that the drive support brackets are oriented so that the flat sides are against the disk drives (channel side out) and the slotted holes on the bracket can align with the mounting holes on the drives. (The end of the bracket with the holes nearest the end will be towards the front of the module.)
- 5) Align each disk drive so that is perpendicular to the printed circuit board and secure it to the drive support brackets using 6-32x1/4" screws (not included) **with Loctite solution**. When all drives are properly aligned, tighten the brackets to each end of the drive module.

- 6) Secure the front cover to the drive module using 8-32x1/4" hex head screws. Use caution when installing front cover making sure the LEDs on the drive module printed circuit board align properly with the four holes on the front cover.

