

Mark 5A 'Piggyback' Setup

Alan R. Whitney
MIT Haystack Observatory
22 September 2003

Some operations with Mark 5A are now conducted in a so-called 'piggyback' mode where both a Mark 4 tape drive and a Mark 5A are connector to a formatter. This is a non-standard mode which requires a non-standard setup of the Mark 5A.

'Normal' Mark 5A Setup

Figure 1 shows the standard interconnections between the Mark 4 formatter, the Mark 5A I/O Panel and the internal Mark 5A I/O Board. In this configuration, the formatter Headstack 1 and Headstack 2 outputs are connected to the Set 1 and Set 2 Inputs on the I/O Panel to set up a 64-track connection to the Mark 5A.

Preferred 'piggyback' Configuration

In the 'piggyback' configuration, the formatter Headstack 1 output is used to drive 32 tracks of the tape drive in the normal manner, while the Headstack 2 output is routed to the Mark 5A Set 1 input. The problem is that the formatter Headstack 2 output is carried on 40-pin connectors (J7 and J8) while the normal Mark 5A I/O Panel Set 1 input is on 50-pin connectors (J5 and J6).

Figure 2 shows how this problem can be overcome by a slight rewiring from the I/O Board to the I/O Panel so that the 40-pin Mark 4 Set 2 connectors can substitute for the Set 1 connectors, allowing an easy connection from Headstack 2 of the formatter.

Alternate 'piggyback' Configuration

As shown in Figure 3, the Mark 5A may be left in its normal configuration and a 40-pin to 50-pin adapter may be used to connect from the formatter Headstack 2 output to the Mark 5A Set 1 input. A potential disadvantage of this method is that the transmission characteristics of the connection between formatter and Mark 5A are degraded and may not work well at the highest data rates.

Operating Modes

Field System revision level 9.6.9 or later must be used to support the piggyback configuration. Three modes of operation are supported in the 'piggyback' wiring configuration:

1. Tape only: this is the default mode of operation
2. Mark 5A only: All recording is on the disk system alone ('drudg' option 11, then select 'Mk5APigW').
3. 'Piggyback' mode: both tape and Mark 5A are recorded simultaneously ('drudg' option 13).

The following notes are extracted from fs9609.txt:

"When using piggyback mode, equip.ctl should not mention MK5A or MK5A_BS, just the tape drive to be used. The correct piggyback option (5A or 5P) in DRUDG must be selected when generating the .snp and .prc files.

1. Piggyback Mark 5A. In this mode the Mark 5A is a secondary recorder. This mode is designed to be used as a "backup" when the primary recording is being done using tape. In this mode the setup is slightly different depending on whether the formatter is Mark4 or VLBA. The Set 1 Mark 5A input is connected to the:
 - a. (Mark4 formatters) the second headstack output of the formatter.
 - b. (VLBA formatters) second recorder output of the formatter.
2. Note that this mode is restricted to less than 33 channels.
3. Mark 5A Pigwire. In this mode the Mark 5A recorder is the primary recorder, but it is hooked up as if it were in piggyback mode. This mode is restricted to 32 tracks. The advantage of this mode is that during the transition period some experiments will be recorded onto tape, whereas others will be recorded onto the Mark 5A recorder. By recording in Mark 5A Pigwire mode, you can keep both a tape recorder and a Mark 5A recorder connected to the formatters.”

Comments

In all configurations, but particularly if you are planning to use 18 MHz clock rates between the formatter and Mark 5A, high-quality cabling of the shortest practical length should be used.

In ‘piggyback’ scheme there is no connection from the Mark 5A back to the decoder, so the only method of checking data is internal checking of recorded data on the Mark 5A.

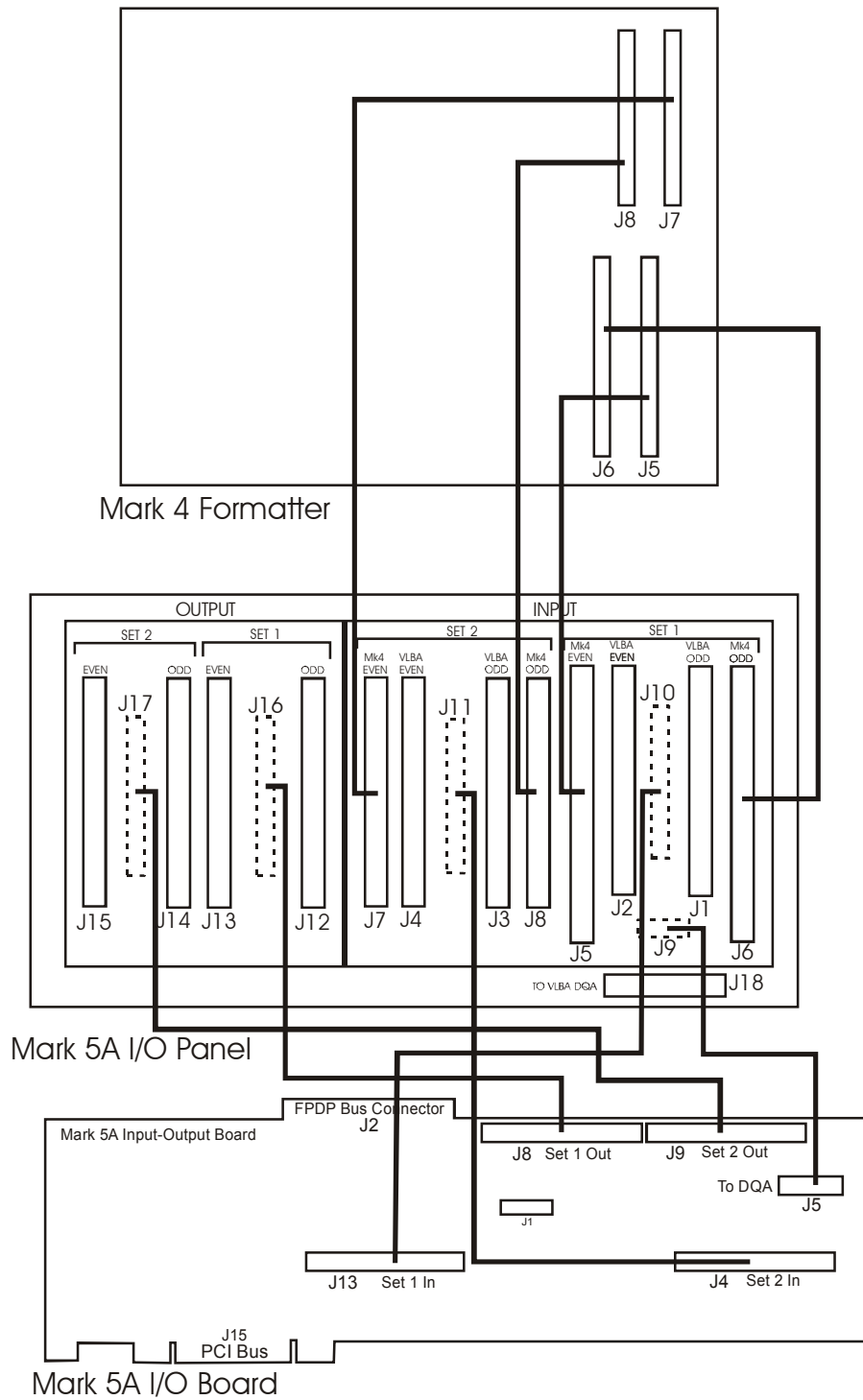

Figure 1: 'Normal' Mark 5A interconnections

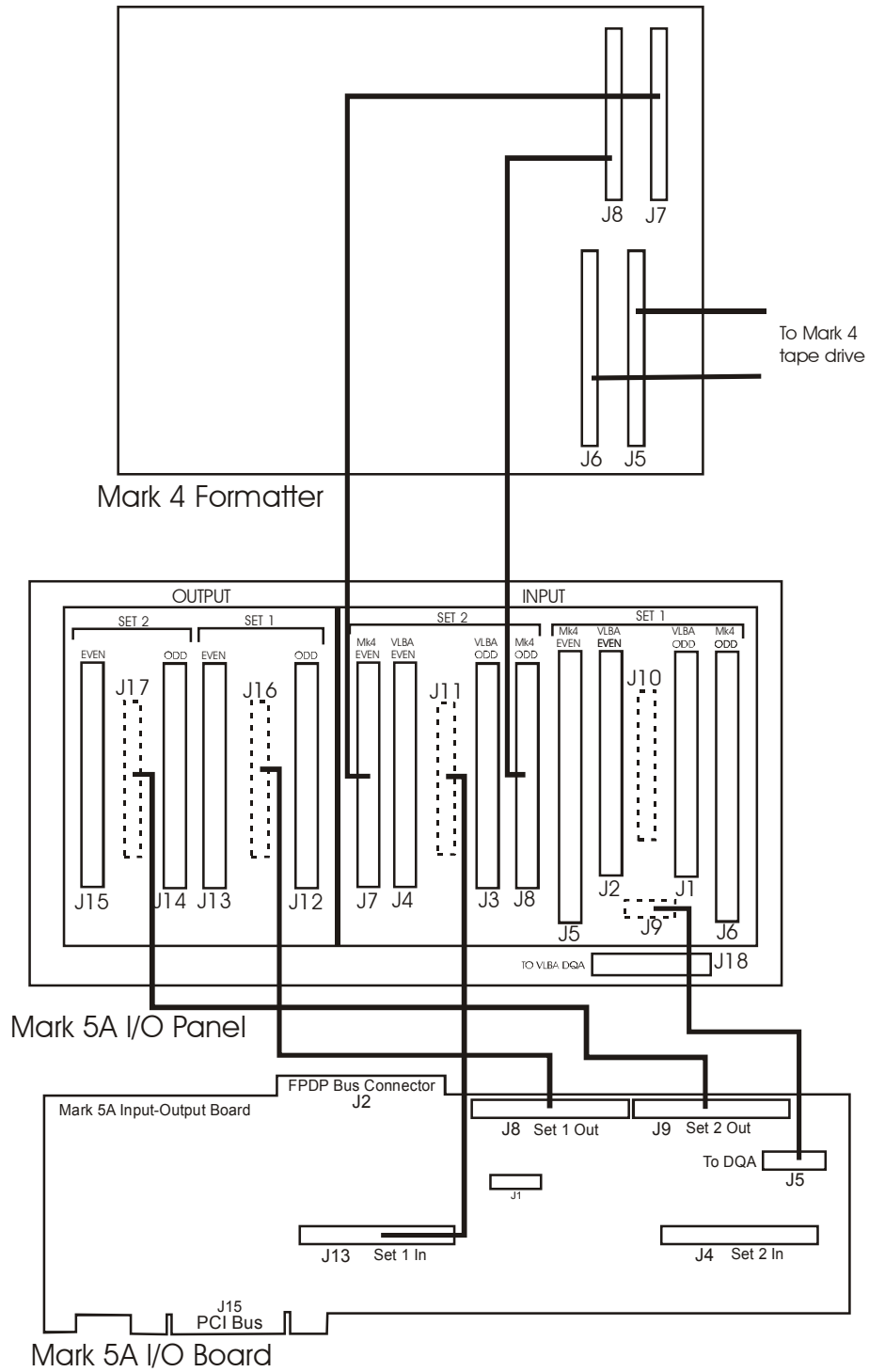

Figure 2: Preferred Mark 5A 'piggyback' interconnection scheme

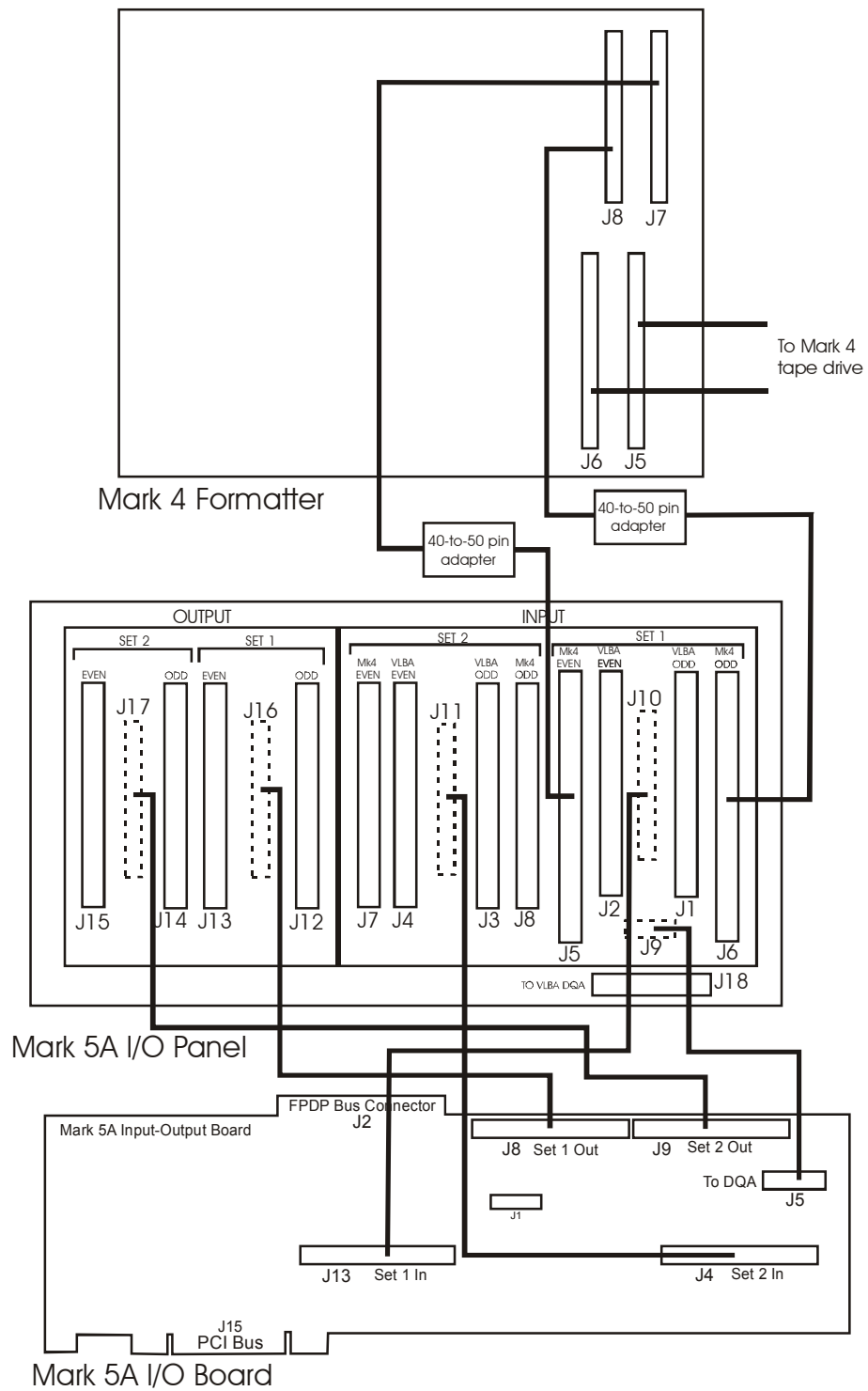

Figure 3: Alternate Mark 5A 'piggyback' interconnection scheme