

MASSACHUSETTS INSTITUTE OF TECHNOLOGY
HAYSTACK OBSERVATORY
WESTFORD, MASSACHUSETTS 01886

March 11, 2003

Telephone: 978-692-4764
Fax: 781-981-0590

To: Mark 5 Development Group

From: Roger Cappallo

Subject: Recently Discovered Model Problems in the Mark 4 Correlator

SUMMARY

While testing routine software enhancements in the Mark 4 correlator software, it was noticed that there were significant errors in the current rotator model. After extensive investigation, it has transpired that there were actually four distinct errors, two having to do with the treatment of acceleration, and two related to a feature in the correlator chip that advances/retards phase on X station bit-shifts. The effect of the acceleration errors is to introduce phase errors in the digital phase rotator that are roughly proportional to both observing frequency and acceleration. The bit-shift related errors are proportional to fringe rate, although they also depend on sample rate; they are particularly severe under conditions of high fringe rates, such as those encountered on long baselines in mm VLBI, or when there are artificially large fringe rates due to LO offsets. The nature of the errors will be elaborated below, and model changes to circumvent the problems will be presented.

Due to the dependence of the problems on baseline length, there are systematic errors in the correlator output. For astronomy programs the effect is primarily to lower visibility amplitudes for long baselines, leading to over-estimates of source sizes. For one particularly bad test scan at 3 mm on a long baseline having a 500 KHz LO offset, the change in amplitude was a factor of 2.4. For geodetic observing, where the frequencies are an order of magnitude lower, the effect is much less. Nevertheless, delays on long baselines have been noted to be systematically affected at a level close to the standard error of the group delay measurement.

ACCELERATION MODEL

The hardware implementation of the Mark 4 fringe rotator is depicted in Figure 1. There are three key registers that hold the fringe phase, phase-rate, and phase-acceleration. The signal marked SysClk is a 32 MHz square wave, and the phase and phase-rate registers are updated every k and n sysclks, respectively. By judiciously choosing values for the acceleration register and n , the phase-rate update period, one can approximate the true acceleration. Unfortunately, we were injudicious.

Problem 1: The old model chose values of n so small, that for many baselines the appropriate value for the acceleration register was less than 0.5, and was rounded down to 0. This had the effect of applying no acceleration for the duration of the correlator frame, which is nominally 500 ms. Even for long baselines, when the rounded value was non-zero, the fractional error in the acceleration value due to rounding was quite large (as much as 0.5 part in 1, 2, or 3).

Problem 2: There was an outright error in the conversion chain from the quintic spline polynomial, which represents the phase smoothly over a 1 minute duration, to the quadratic polynomial that is fit to the spline over the duration of the correlator frame, and finally to the values for n , k , and the three phase registers within the correlator chip. The problem was that the coefficient of the quadratic term was interpreted as acceleration, when in fact it was just the t^2 power series coefficient, which is a factor of 2 smaller. The sense of the error was that the value loaded into the acceleration register was too small by (roughly, due to the above-mentioned round-off) a factor of 2.

The new acceleration model determines the value of the acceleration register, which is usually a single digit integer. If it is 0, it is forced to be 1. Then n is chosen such that the effective acceleration is as close as possible to the true acceleration. Since n is typically a 4 or 5 digit number, the fractional error in the acceleration so determined is about 1 part in 10^5 .

Since the optimal n has to be chosen on a baseline basis, the above calculations are performed within the correlator service software (the bos program), rather than in the SU's, where the rest of the model calculations are done. This required a change in the definition of the format of the correlator frame header packet, so as to carry the acceleration values for each station with as much precision as possible.

Damage Assessment – In order to ascertain the extent of the above errors in a given scan, one can use the acceleration as listed on the fourfit plot, and multiply it by the observing frequency, in order to find the phase acceleration. The acceleration error term, ϵ , can be

as much as $\frac{1}{2}$ of this value, that is $\epsilon \leq \frac{1}{2} \ddot{b} f$, where \ddot{b} is the baseline acceleration, and f is the observing frequency. If P is the length of the correlator frame (nominally 0.5 sec), the loss of coherence would then reduce the amplitude by the amount shown below:

$$\frac{A}{A_{true}} = \int_0^P \cos(0.5\epsilon t^2) dt$$

There would also be a resultant phase offset in the channel, of magnitude $\epsilon P^2 / 6$.

PROBLEM WITH PHASE DOUBLE/NULL INCREMENT

The Mark 4 correlator chip has a feature that was causing additional problems, particularly under conditions of high fringe-rates. Whenever there are samples duplicated/deleted from the X data stream, the phase register is automatically null/double incremented by the amount in the phase-rate register. The motivation for this behavior is that the X data stream is mixed with the rotator and passes along through the lag registers, being correlated as it goes. Since the time tag implicit for each X data sample undergoes a discontinuity on the sample shift, it was deemed appropriate to make a correction to the phase model that goes along with the X data. A similar mechanism was used successfully in the Mark 3 correlator, where the time base for all operations was the X station time.

However, in the Mark 4 correlator, we keep time independently of either station – by the so-called ROT clock, which is a virtual clock at the center of the earth. The model calculations are done with respect to ROT as the independent variable, and the delay applied to the data within the station units is done with respect to ROT.

Note that this feature is different from the hardware bit-shifting phase advance, which adds or subtracts 90 degrees (for Nyquist-sampled data) whenever the *baseline* undergoes a delay change of one sample, thus compensating for the mean phase change across the video band. There are no currently known problems in this latter feature.

Problem 3: It is inappropriate to modify the rotator phase based on bit-shifting of the X data stream. Although the model calculations could be modified to take this into account, it is cleaner and preferable to defeat this feature altogether. We have done so by setting the delay generators at the head of a correlation snake to 0, so that there are no X carries, and thus no phase double/null increments. Note that the delay generators at the tail of the snake still need to be set to the proper values, so that the vernier delay bit is controlled correctly.

The remaining problem (#4) is now only of academic interest, in that the changes above defeat the action of the phase double/null increment circuitry. Should it be decided to re-enable this feature in the future, one will want to look carefully at the following problem.

Problem 4: The increment applied on X station shifts is wrong, even if the model values were calculated with respect to X station time. The phase increment amount (contained in the phase-rate register) is appropriate for being added every k sysclks of X station time, while the amount that *should* be added is the phase change over one X sample period. These two time values – the sample period and k sysclks - are not tied together at all. An ad hoc solution would be to arrange to pick k such that the sysclk frequency divided by k is the sample rate. Although this would probably work, it would subvert the purpose for which k was intended, leading to a non-optimal loss of fringe rate resolution, and setting a limit to the maximum fringe rate that can be handled.

Damage Assessment – The net effect of problem 3 is that there is an error in fringe rate that is proportional to fringe rate. Quantitatively, the error is

$$\Delta\dot{f} = \frac{k}{32e6} (f\boldsymbol{\epsilon} + \mathbf{d}f_{LO})\boldsymbol{\epsilon}_x f_s$$

where f is the observing frequency, $\boldsymbol{\epsilon}$ is the baseline delay rate, $\mathbf{d}f_{LO}$ is any LO offset, $\boldsymbol{\epsilon}_x$ is the X station delay rate, and f_s is the sample rate. The loss in amplitude is given by

$$\frac{A}{A_{true}} = \int_0^P \cos(\Delta\dot{f}t) dt = \frac{\sin(P\Delta\dot{f})}{P\Delta\dot{f}} - 1$$

and the resultant error in the phase is simply $\Delta\dot{f}P/2$.

SOFTWARE CONSIDERATIONS

Since changes to the correlator frame header block were necessary, in order to support increased accuracy in the acceleration model, the operational software needs to be changed in two places concurrently. The control software for the station units has been modified to create the new header packets; it is found in /usr/tftpd/sudev/ram.hex. Of course, the station units will need to be rebooted to the new code after installation. Also the correlator driver software, found in \$BINRT/bos, has also been modified, in order to do the baseline-based corrections to the acceleration update period. Both changes will come together in a single tarball release of the correlator software.

A good test of the model integrity is to compare the results of (otherwise identical) correlations run with different length correlator frames. If the software is working correctly there should be little difference (say a fraction of a degree in phase, and well under 1% change in amplitude). The old rotator model fails this test rather badly, while the new code performs well at sample rates under 32 MS/s. At 32 MS/s though, there appears to be some unrepeatable station unit related errors (likely a single bit offset in delay of some occasional correlator frames) which cause a loss of amplitude (several percent). When correlating at 32 MS/s, it might be prudent to use 250 ms. correlator frames until the SU problems can be corrected.

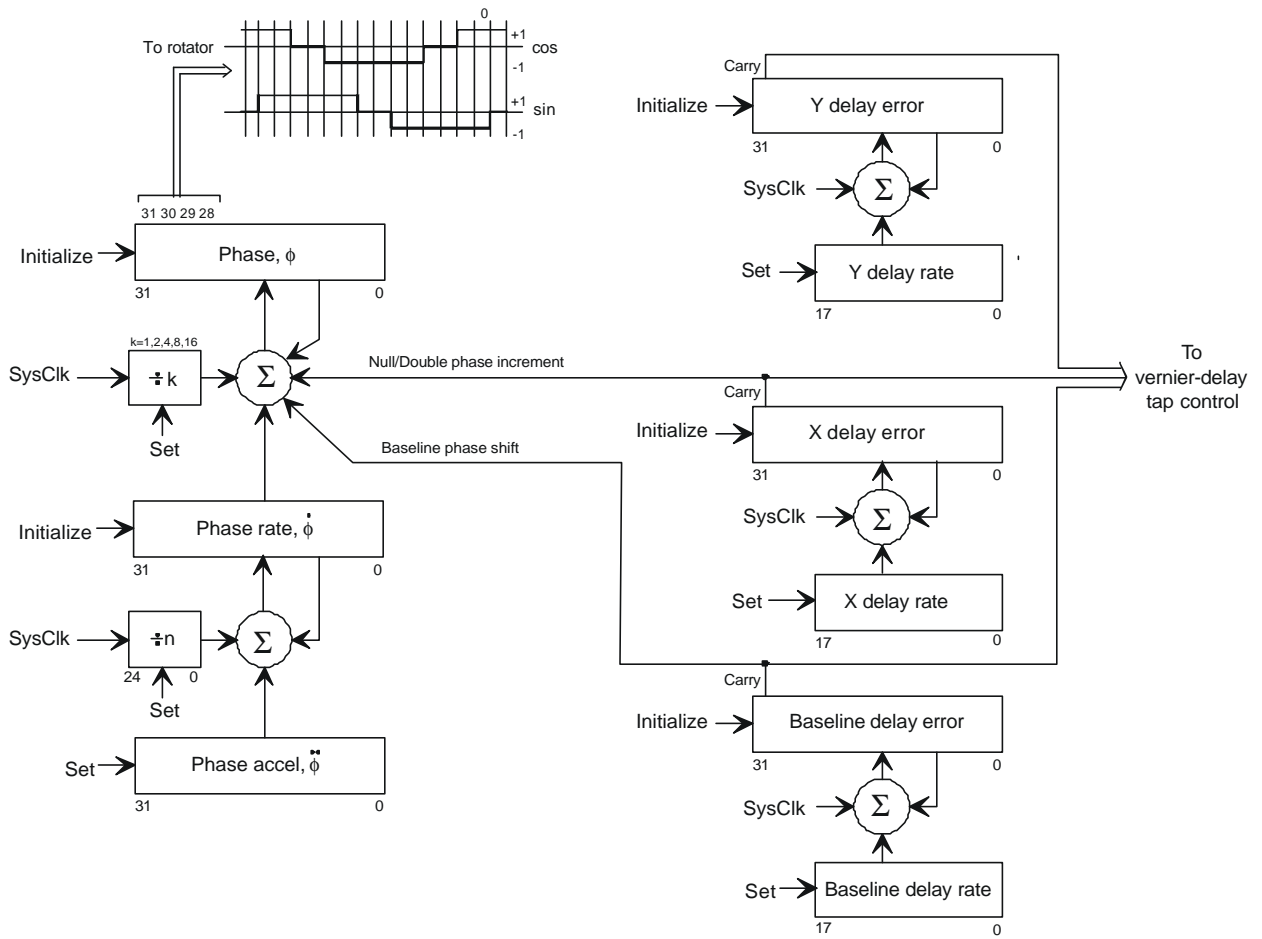

Figure 1: Phase/Delay Generator Block Diagram