

MASSACHUSETTS INSTITUTE OF TECHNOLOGY
 HAYSTACK OBSERVATORY
 WESTFORD, MASSACHUSETTS 01886

March 11, 2003

Telephone: 978-692-4764
 Fax: 781-981-0590

To: Mark 5 Development Group

From: Roger Cappallo

Subject: Optimally Setting the *kdiv* Parameter in the Mark 4 Correlator

SUMMARY

The Mark 4 correlator chip has a feature, inherited from the Mark 3a correlator, which allows the user some flexibility over how the fringe phase is updated. Referring to Figure 1, it can be seen that the parameter *k* controls the period between phase updates, by dividing the 32 MHz system clock by 1, 2, 4, 8, or 16. When *k* is set to its highest value of 16, one obtains the best possible resolution in fringe rate of the digital rotator, since the round-off error is added in least frequently. At the other extreme, when *k* is 1, the maximum possible fringe rate (± 16 MHz) is possible.

Until recently our strategy in setting *kdiv* (note that $k = 2^{kdiv}$ for $kdiv = 0..4$), was to choose *kdiv* as large as possible, while ensuring that the maximum fringe rate was still within range of the rotator. It turns out that this is not the best strategy, because errors are introduced by keeping the phase fixed during the *k* clock periods, which can negate the gains due to more accurately approximating the fringe rate. A new formulation was derived, and has now been implemented in the *suman* code that sets *kdiv* for a scan.

DERIVATION

First define:

- c system clock rate (nominally 32 MHz)
- k divisor for phase update period ($= 2^{kdiv}$)
- N correlator frame length (samples)
- f sample rate (samp/s)
- w fringe rate (Hz)

Then the fringe rate resolution, Δf , is

$$\Delta f = \frac{c}{2^{32} k} \text{ (Hz)}$$

The resulting phase error at the end of a correlator frame, \mathbf{dE} , is then

$$\mathbf{dE} = \pm \frac{1}{2} \cdot \frac{c}{2^{32}k} \cdot \frac{N}{f} \text{ (rot)}$$

The maximum phase error, \mathbf{dP} , experienced during one fringe update period (k/c sec) is

$$\mathbf{dP} = \pm \frac{1}{2} \cdot \frac{k}{c} \cdot \mathbf{w} \text{ (rot)}$$

We will want to choose k such that the two maximum error magnitudes are equal.

Setting $|\mathbf{dE}| = |\mathbf{dP}|$, we have

$$\frac{1}{2} \cdot \frac{c}{2^{32}k} \cdot \frac{N}{f} = \frac{1}{2} \cdot \frac{k}{c} \cdot \mathbf{w}$$

which leads to an expression for the optimal value of k :

$$k = \sqrt{\frac{Nc^2}{2^{32}f\mathbf{w}}}$$

Now, since k can only take on the values of $\{1, 2, 4, 8, 16\}$ the software in *suman* finds the closest (in the logarithmic sense) allowable value, and sends that value to the station unit during scan configuration.

EXAMPLES

Example 1: Astronomy from a CMVA worst case

$$N = 16 \times 10^6 \text{ samples}$$

$$c = 32 \times 10^6 \text{ Hz}$$

$$f = 32 \times 10^6 \text{ samp/s}$$

$$\mathbf{w} = 350 \text{ KHz}$$

Optimal k is then 0.58, which would lead to $\mathbf{dE} = \mathbf{dP} = 1.2^\circ$. If we choose the nearest allowable value for $k = 1$, then $\mathbf{dE} = 0.67^\circ$, $\mathbf{dP} = 1.97^\circ$.

Example 2: Geodesy (typical X band long baseline obs.)

$N = 8 \times 10^6$ samples
 $c = 32 \times 10^6$ Hz
 $f = 16 \times 10^6$ samp/s
 $w = 10$ KHz

Optimal k is then 3.45, which would lead to $dE = dP = 0.19^\circ$. If we set k to the nearest allowable value of 4, then $dE = 0.17^\circ, dP = 0.23^\circ$.

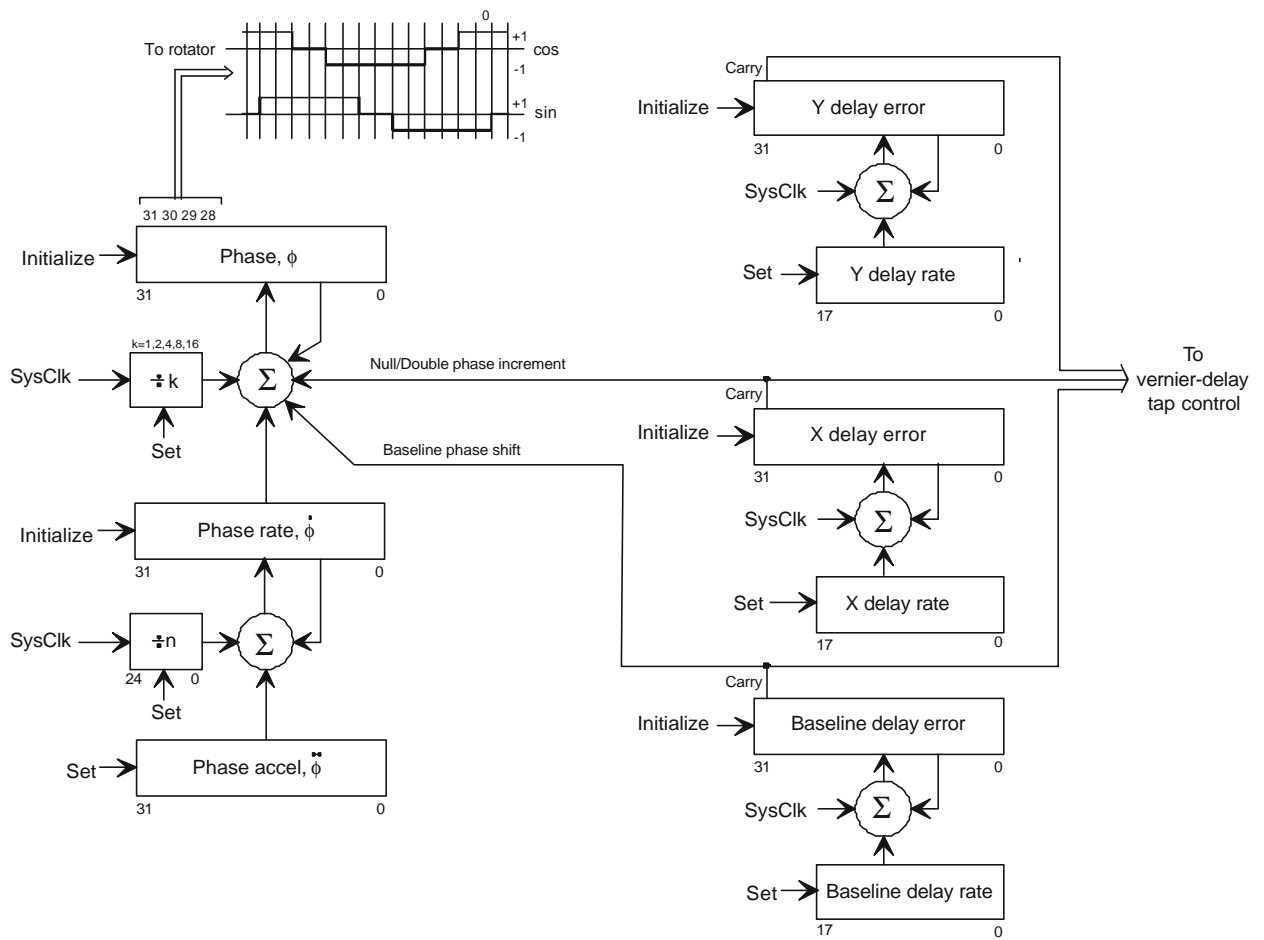

Figure 1: Phase/Delay Generator Block Diagram