

MASSACHUSETTS INSTITUTE OF TECHNOLOGY

HAYSTACK OBSERVATORY

WESTFORD, MASSACHUSETTS 01886

Telephone: 978-692-4764

Fax: 781-981-0590

17 August, 2006

TO: Mark 5 group
FROM: Alan E.E. Rogers
SUBJECT: 1024/2048 MHz clock synthesizer for DBE

A synthesizer for the DBE has been constructed using a National semiconductor LMX2531LQ2080E.

The circuit is shown in Fig. 1

There are 2 jumpers. One selects 1024 and 2048 MHz SW1 and the other, J1, elects 5 or 10 MHz reference.

The performance is as follows:

Phase stability < 1ps/degC

Phase jitter < 1 ps rms

Buffered outputs +6dBm (needs 12 dB attenuators to drive ADC)

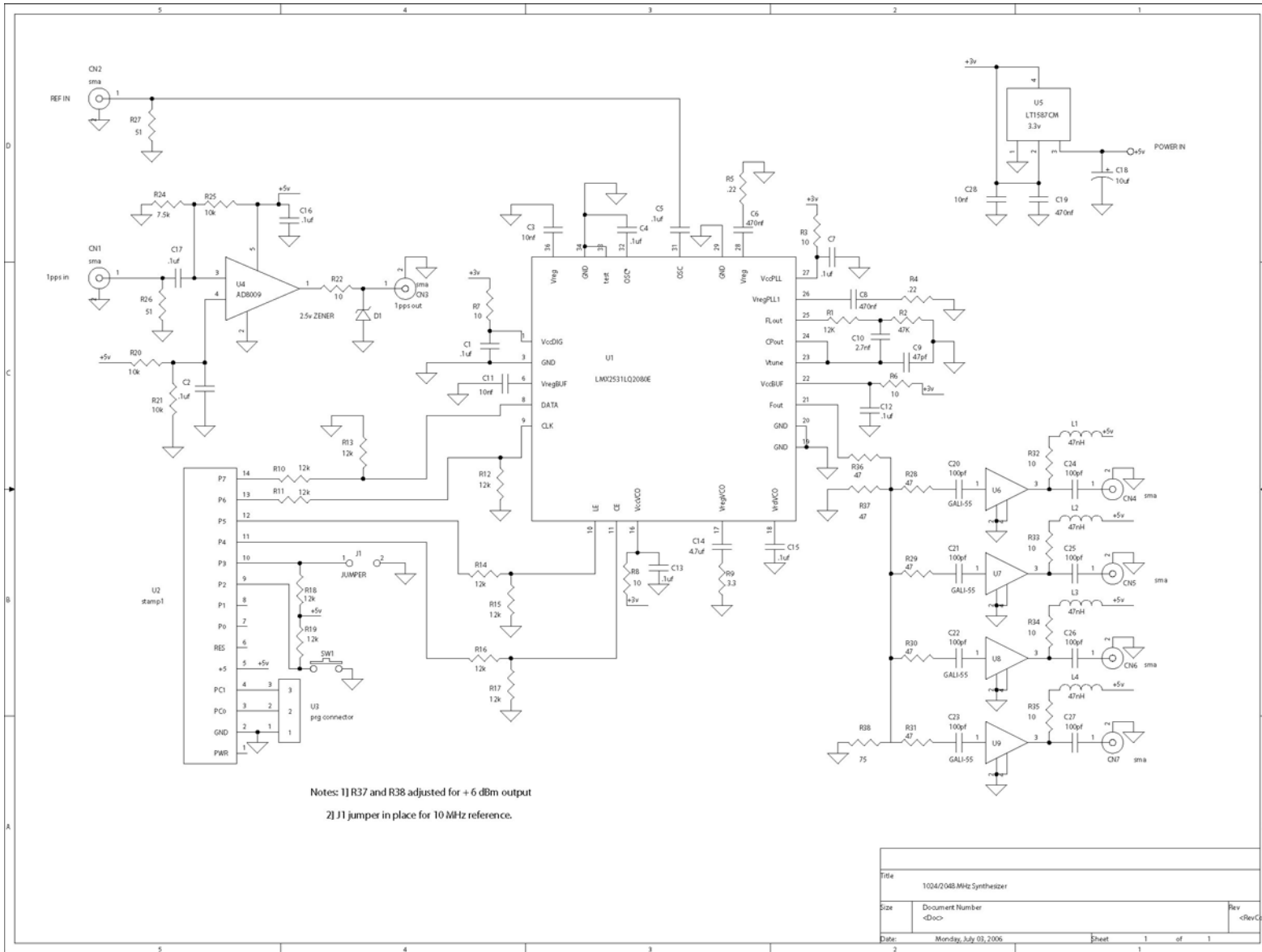

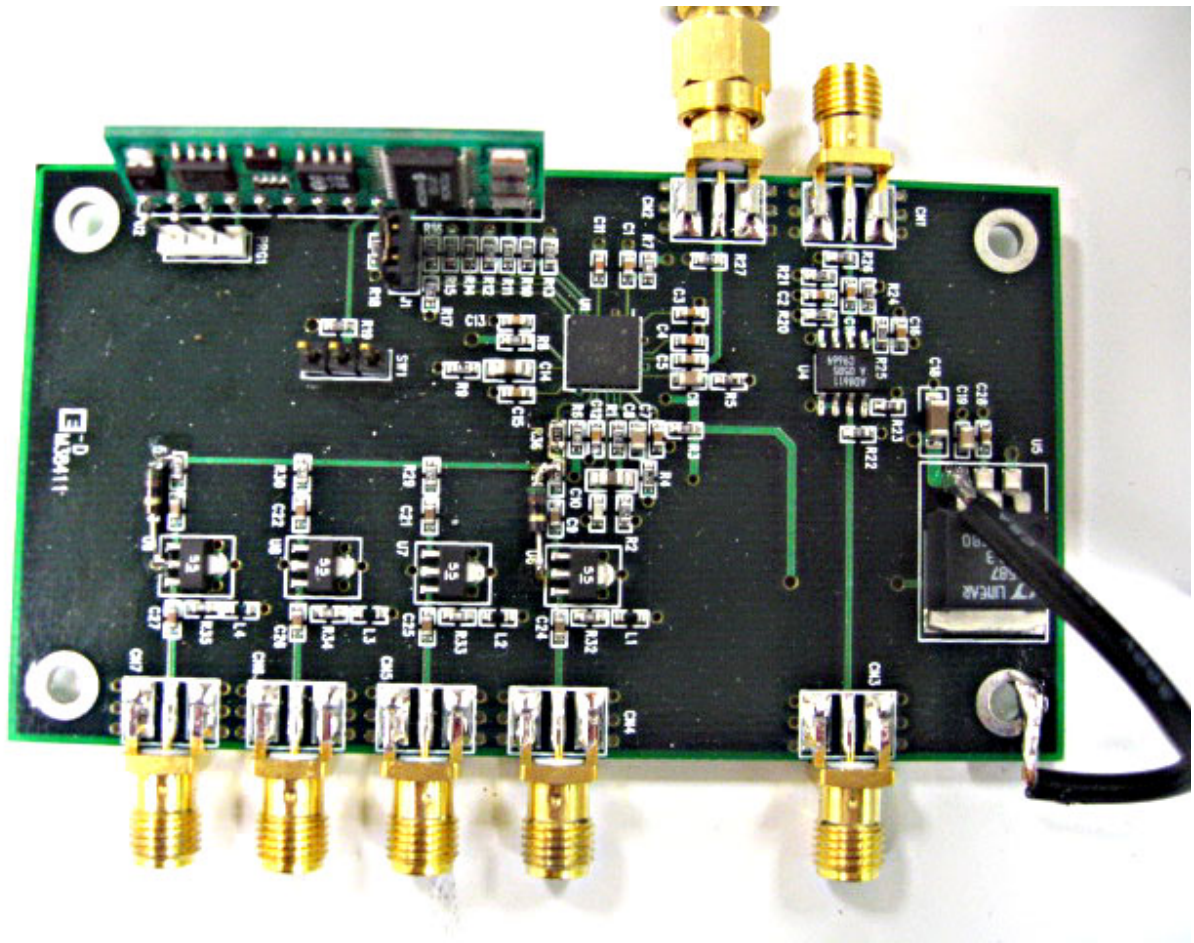

Fig. 2. 1024/2048 MHz Synthesizer

```

' {$STAMP BS1}
' pin0 = NC
' pin1 = NC
' pin2 = switch for 1024/2048
' pin3 = Switch for 5/10 MHz
' pin4 = Chip enable
' pin5 = LE
' pin6 = CLK
' pin7 = DATA

        DIRS=%11110000                'initial I/O
set
        PIN4=1                        'enable chip
        PAUSE 1000
        PIN5=1                        'disable cmd
'init1  B0=%10000100: B3=%00000000: B4=%00000101: GOSUB syn
'init2  B0=%10000000: B3=%00000000: B4=%00000101: GOSUB syn
start:  B0=%10000000: B3=%00000111: B4=%11110101: GOSUB syn 'R5
'
        PAUSE 1000
        B0=%00000001: B3=%00000100: B4=%10001100: GOSUB syn 'R12
        B0=%00000000: B3=%00010001: B4=%10101001: GOSUB syn 'R9
        B0=%00000011: B3=%00000000: B4=%00001000: GOSUB syn 'R8
        B0=%00000000: B3=%00010101: B4=%00000111: GOSUB syn 'R7
        B0=%01001000: B3=%11100110: B4=%01010110: GOSUB syn 'R6
        B0=%00000000: B3=%00000000: B4=%00000100: GOSUB syn 'R4
        B0=%10111100: B3=%00000000: B4=%00000011
        IF PIN2=1 THEN nnxx
        B0=%00111100          ' 2048 MHz
nnxx:   GOSUB syn 'R3
        B0=%01000110: B3=%01000000: B4=%00010010          'R2
        IF PIN3=1 THEN nnxt
        B4=%00100010          ' 10 MHz ref
nnxt:   GOSUB syn 'R2
        B0=%00100000: B3=%01000000: B4=%00000001: GOSUB syn 'R1

```

```

        B0=%10011001: B3=%00001111: B4=%00000000: GOSUB syn 'R0
done: PAUSE 60000
'infinite loop
        GOTO done
'        PAUSE 2000
'        GOTO start
syn: PIN5=0
        FOR B6 = 1 TO 2
        FOR B5 = 1 TO 8                                'loop for 8
bits
        PIN7=BIT7
'        DEBUG BIT7                                    'msb of b0
        PULSOUT 6,1                                    'pulse clock
line
        B0=B0*2                                        'left shift
one bit
        NEXT
        B0=B3
        NEXT
        B0=B4
        FOR B5 = 1 TO 8
        PIN7=BIT7
'        DEBUG B4
        PULSOUT 6,1
        B0=B0*2
        NEXT
        PIN5=1
'        PAUSE 1000
        RETURN

```