

MASSACHUSETTS INSTITUTE OF TECHNOLOGY
HAYSTACK OBSERVATORY
 WESTFORD, MASSACHUSETTS 01886
 Updated August 30, 2010

Telephone: 781-981-5407
 Fax: 781-981-0590

To: Mark 5 Group
 From: Alan E.E. Rogers
 Subject: Performance characteristics of Updown converter

Performance results based on the block diagram of figure 1 are as follows:

Input frequency range	1-13 GHz
Up conversion L.O. range	23-33 GHz
Up conversion I.F. range	20-22 GHz
Down Conversion L.O.	22.5 GHz
I.F. range prior to Nyquist filters	0.5-2.5 GHz
Output Frequency	22.5 – 4x luff + input GHz
Luff frequency range	5.75 – 8.25 GHz
Minimum step size	100 kHz
Bandpass ripple	4 dB peak to peak
Minimum size for repeatable phase	1 MHz
Nominal input power ¹	-30 dBm
Spurious rejection ² (excluding L.O. Sidebands)	-70 dB
Spurious signals (Luff 3 rd harmonic) ³	-50 dB
Spurious signals (excluding luff 3 rd harmonic)	-70 dB
Conversion gain (atten. 0 dB)	60 dB
(atten. 30 dB)	30 dB
Noise figure	8 dB
Cross-talk between pol. Channels	~-50 dB
Coherence loss due to phase noise	~0.5% (~5° rms)

Notes:

- 1] Nominal input power of -30 dBm implies that a 12 GHz bandwidth LNA and 2nd stage with 50 K system needs 50 dB gain to supply the nominal signal level to the updown converter.
- 2] Spurious rejection is the rejection of unwanted responses due to images etc. relative to the desired signal.
- 3] Spurious signals levels are signals which originate in the updown converter measured relative to the nominal input level. The worst offender is the 3rd harmonic of the Luff synthesizer which lies within the passband for L.O. settings between 6.667 and 7.333 GHz. These correspond to an input range of 6.667 to 7.333 GHz.
- 4] Recent measurements at the Westford site show radar signal levels can leak into the sidelobes of the broadband feed at a level of up to about -40 dBm. In this case it would be better to use an LNA with about 28 dB gain before the updown converter to ensure the

first mixer sees no more than 0 dBm. The updown converter will contribute about 3K out of a 53 K system and the interference free input level to the converter will be -41 dBm/12 GHz and the outputs to the DBE will be between -25 to +5 dBm/500 MHz depending on the attenuator setting.

Local control:

The STAMP code displays the Luff frequency in MHz and the attenuator settings in dB. The display alternates between the frequency and attenuator settings. The attenuator values are given as channel A then channel B separated by a period. To manually change the frequency or attenuators press and hold down the push button switch until the digit you want to change is flashing then pulse the switch to increment the digits. When complete hold down the button until the normal (not flashing display) is reached. An out of lock condition or illegal frequency is indicated by flashing decimal points.

Remote control:

The control remotely send the keyword "freq" followed by the frequency (in MHz) attenuator 1 (in dB), attenuator 2 (in dB) followed by a CR at 9600 band.

The unit should respond with

Freq xxxx yy zz OK CR

In in lock or

Freq xxxx yy zz errcode CR

If there is an error or the unit doesn't lock. The local remote display will also show the settings.

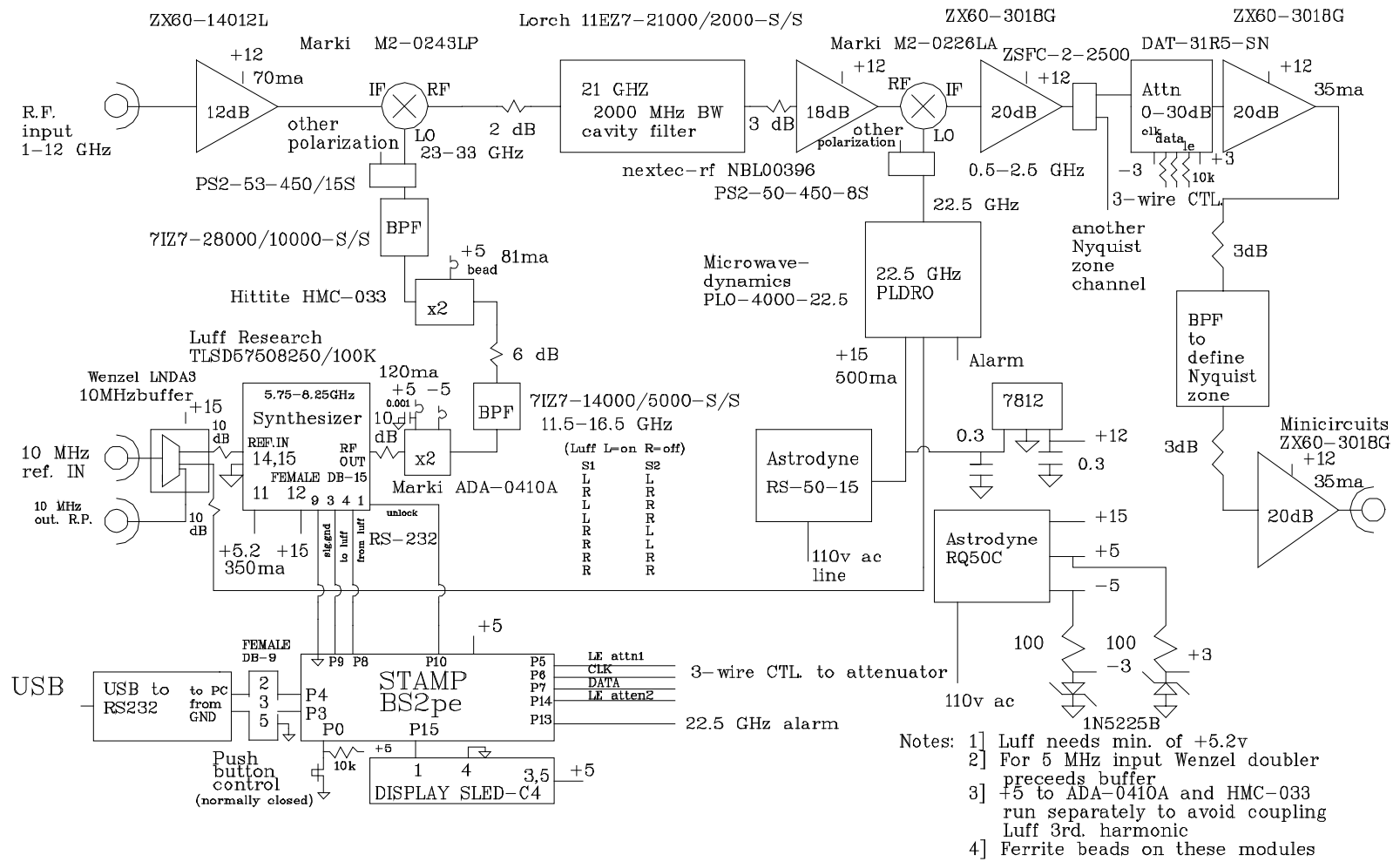

Simplified block diagram for connectorized up/down converter for DBE

aer 13oct07

Figure 1 Block diagram

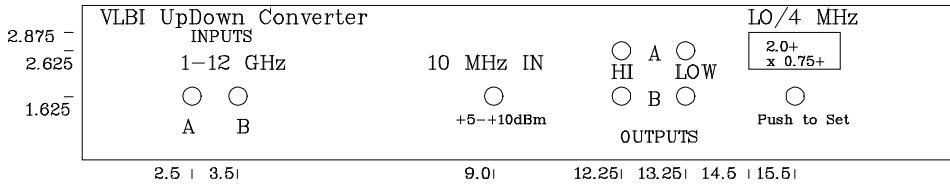

Front panel viewed from the front
holes are all 0.250"

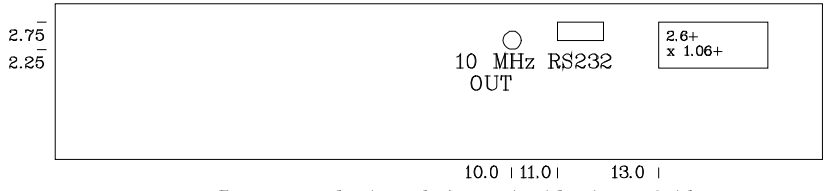

Rear panel viewed from inside to outside

Updown
panels
aer 13oct07

Figure 2 Updown panels

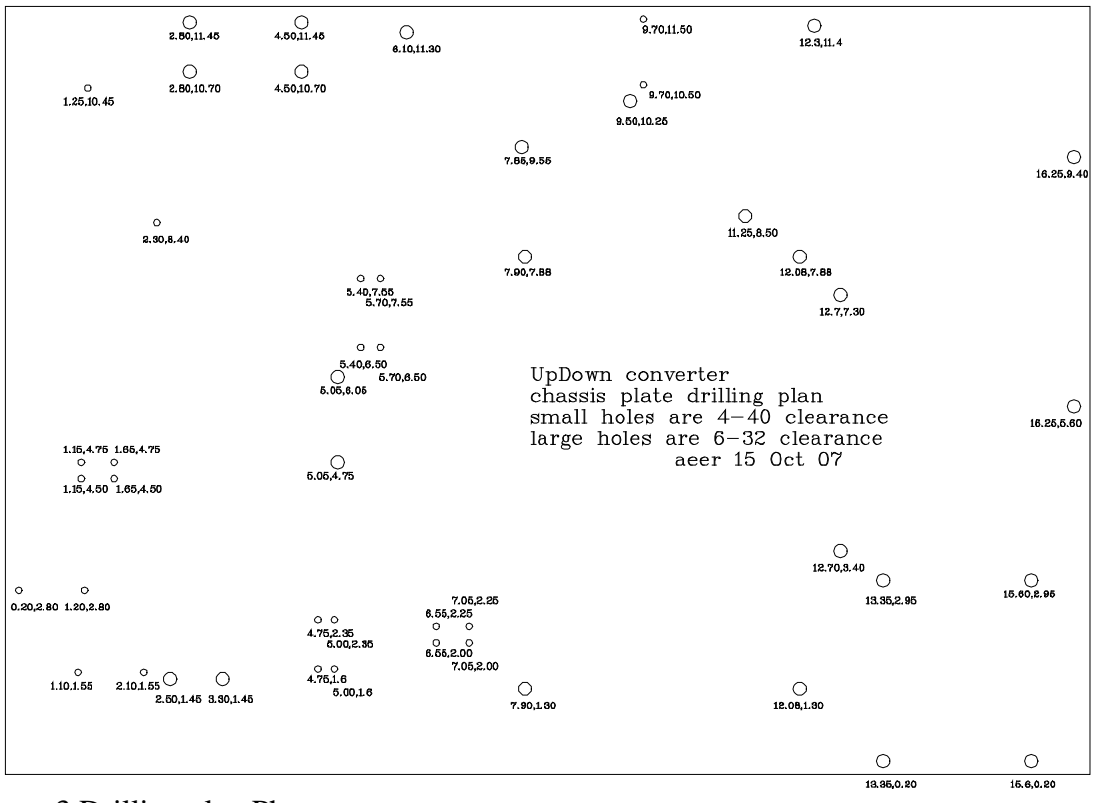

Figure 3 Drilling plan Photo

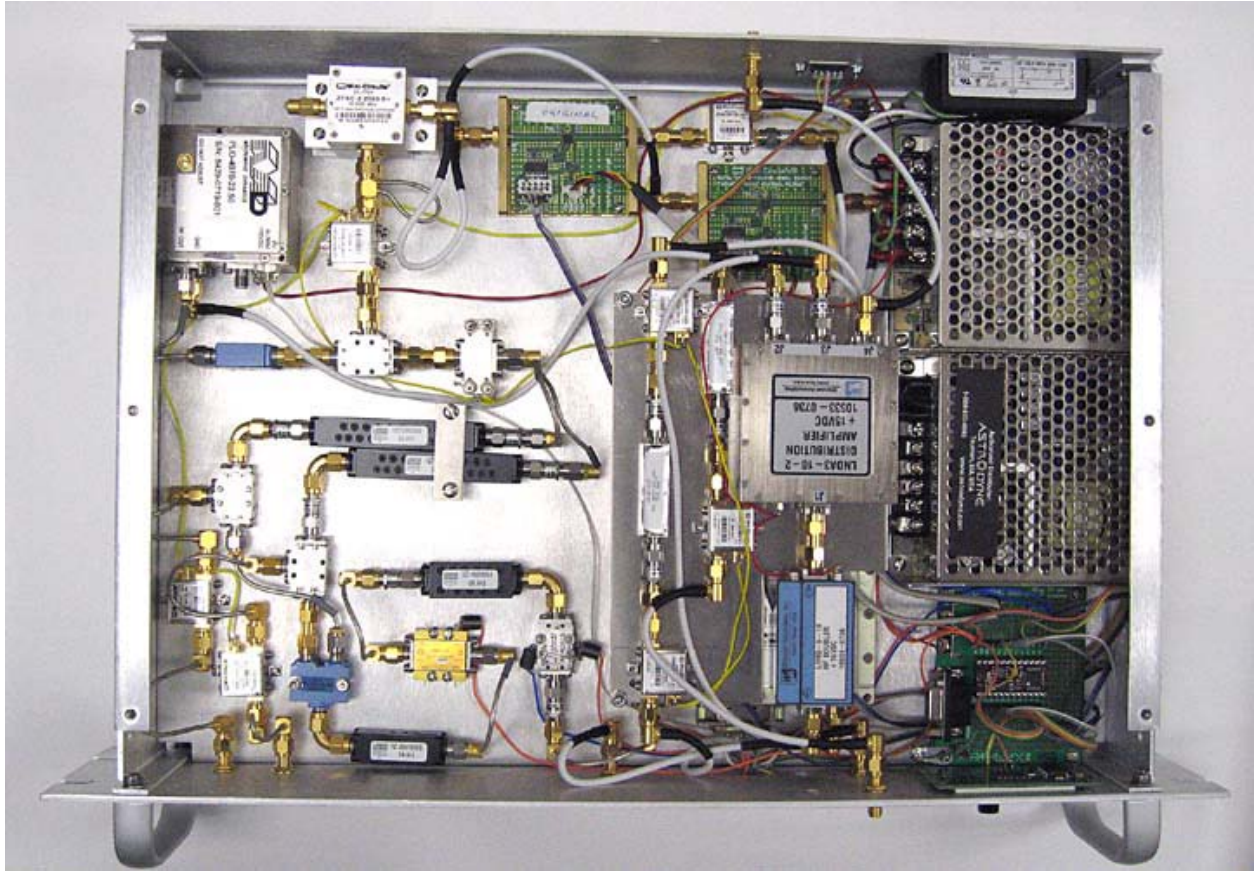

Figure 4 Photo

```

' {$STAMP BS2pe}
bb VAR Nib
freq VAR Word
freqp VAR Word
freq3 VAR Nib
freq2 VAR Nib
freq1 VAR Nib
freq0 VAR Nib
frq3 VAR Nib
frq2 VAR Nib
frq1 VAR Nib
frq0 VAR Nib
attn VAR Byte
attn1 VAR Byte
attn2 VAR Byte
attn1p VAR Byte
attn2p VAR Byte
ttn11 VAR Nib
ttn10 VAR Nib
ttn20 VAR Nib
ttn21 VAR Nib
fh VAR Nib
prs VAR Bit
alt VAR Bit
alt2 VAR Bit
attn11 VAR Nib
attn10 VAR Nib
attn21 VAR Nib
attn20 VAR Nib
cnt VAR Byte
sw VAR Bit
lock VAR Bit
fhh VAR Bit
outr VAR Bit
lock2 VAR Bit
rcv VAR Bit
pau VAR Byte
serstr VAR Byte(4)

```

```

'p5 LE for attn1
'p6 CLK
'p7 DATA
'p14 LE for attn2
'p8 rs232 pin 2 from luff
'p9 rs232 pin 3 to luff
'p4 rs232 pin 2 to PC
'p3 rs232 pin 3 from PC
'p10 rs323 pin4 lock indicator from luff
'p13 alarm from 22.5 GHz PLO
'p0 button
'p15 display data

```

```
DIRS = %1100001011110000
```

```
freq = 5750 'default
attn1 = 6
```

```

attn2 = 7
fh = 0
alt = 0
alt2 = 0
prs = 0
cnt = 0
sw = 0
freqp = 0
fhh = 0
attn1p = 255
attn2p = 255
outr = 0
pau = 5
rcv = 0 'data received flag

start: IF (cnt > 0 AND fhh = 0) OR fh > 0 THEN skp
      SERIN 3,16780,1000,skp,[WAIT("freq"),DEC freq, DEC attn1, DEC attn2]
      rcv = 1
      ' SEROUT 4,16780,["freq ",DEC freq," ",DEC attn1," ",DEC attn2,CR]
      ' SERIN 3,84,1,defau,[DEC freq]
skp:   pau = 40
      IF cnt > 0 AND fh = 0 AND fhh = 0 THEN skpp
      IF cnt > 12 THEN skpp 'increment fh while pressed
      IF cnt > 0 AND cnt < 12 AND sw = 0 AND fhh = 0 THEN skp3
      GOTO skp2
skp3:  prs = 1
      cnt = 0
      GOTO skp2
skpp:  fh = fh + 1
      prs = 0
      cnt = 0
      fhh = 1
      IF fh < 7 THEN skp2
      fh = 0
      alt2 = 0
      alt = 0
skp2:  IF sw = 1 THEN skp4
      fhh = 0
      cnt = 0
skp4:  ' DEBUG "here fh=", DEC fh," cnt=", DEC cnt,"sw ", DEC sw," prs ",DEC prs,CR
      GOSUB disp
      GOSUB atten1
      GOSUB atten2
      GOSUB luff
      GOSUB plo
      IF rev = 0 THEN skp5
      IF lock = 0 OR outr = 1 OR lock2 = 0 THEN skp6
      SEROUT 4,16780,["freq ",DEC freq," ",DEC attn1," ",DEC attn2," OK",CR]
      rcv = 0
      GOTO skp5
skp6:  SEROUT 4,16780,["freq ",DEC freq," ",DEC attn1," ",DEC attn2," ",DEC lock+lock2+outr,CR]
      rcv = 0
skp5:  IF fh > 0 THEN skp
      pau = 5
      GOTO start

```

```

disp:  freq3 = freq / 1000
      freq2 = freq / 100 - (freq3 * 10)
      freq1 = freq / 10 - (freq3 * 100) - (freq2 * 10)
      freq0 = freq - (freq3 * 1000) - (freq2 * 100) - (freq1 * 10)
      frq3 = freq3
      frq2 = freq2
      frq1 = freq1
      frq0 = freq0
      attn11 = attn1 / 10
      attn10 = attn1 - (attn11 * 10)
      attn21 = attn2 / 10
      attn20 = attn2 - (attn21 * 10)
      ttn11 = attn11
      ttn10 = attn10
      ttn21 = attn21
      ttn20 = attn20
'
  DEBUG DEC freq3,DEC freq2,DEC freq1,DEC freq0,CR
  IF fh = 0 THEN disp0
  IF fh <> 1 THEN ddisp1
  frq0=10
  IF prs = 0 THEN f1
  freq0 = (freq0 + 1)//10
f1:  alt = 0
ddisp1: IF fh <> 2 THEN ddisp2
      frq1=10
      IF prs = 0 THEN f2
      freq1 = (freq1 + 1)//10
      frq1 = freq1
f2:  alt = 0
ddisp2: IF fh<> 3 THEN ddisp3
      frq2=10
      IF prs = 0 THEN f3
      freq2 = (freq2 + 1)//10
      frq2 = freq2
f3:  alt = 0
ddisp3: IF fh <> 4 THEN ddisp4
      frq3 = 10
      IF prs = 0 THEN f4
      freq3 = (freq3 + 1)//10
      frq3 = freq3
f4:  alt = 0
ddisp4: IF fh <> 5 THEN ddisp5
      ttn21 = 10
      ttn20 = 10
      IF prs = 0 THEN a1
      attn2 = (attn2 + 1)//32
      attn21 = attn2 / 10
      attn20 = attn2 - (attn21 * 10)
a1:  alt = 1
ddisp5: IF fh <> 6 THEN ddisp6
      ttn11 = 10
      ttn10 = 10
      IF prs = 0 THEN a2
      attn1 = (attn1 + 1)//32
      ttn11 = attn1 / 10
      ttn10 = attn1 - (attn11 * 10)

```

```

a2:  alt = 1
ddisp6: IF prs = 0 THEN disp0
      freq = (freq3 * 1000) + (freq2 * 100) + (freq1 * 10) + freq0
      prs = 0
disp0: IF alt = 1 THEN disp2
      IF alt2 = 1 THEN sp0
      IF lock = 0 OR outr = 1 OR lock2 = 0 THEN spp0
      SEROUT 15,84,["P",0,"~","D",freq3,freq2,freq1,freq0]
      GOTO spp1
spp0: SEROUT 15,84,["P",15,"~","D",freq3,freq2,freq1,freq0]
spp1: alt2 = 1
      GOTO sp1
sp0:  SEROUT 15,84,["P",0,"~","D",freq3,freq2,freq1,freq0]
      alt2 = 0
sp1:  PAUSE pau
      alt = 1
      GOTO disp3
disp2: IF alt2 = 1 THEN sp2
      SEROUT 15,84,["D",attn11,attn10,attn21,attn20,"P",2,"~"]
      alt2 = 1
      GOTO sp3
sp2:  SEROUT 15,84,["D",ttn11,ttn10,ttn21,ttn20,"P",2,"~"]
      alt2 = 0
sp3:  PAUSE pau
      alt = 0
disp3: IF IN0 = 0 THEN disp4
      sw = 1
      cnt = cnt + 1
      RETURN
disp4: sw = 0
      RETURN
luff: lock = IN10
      IF freq = freqp THEN luff2
      SEROUT 9,16468,[">03F",DEC freq,"0",CR]
      SERIN 8,16468,100,luff2,[STR serstr4]
      '   DEBUG STR serstr
      outr = 1
      freqp = freq
      IF serstr(3) <> "A" THEN luff2
      outr = 0
      '   freqp = freq
luff2: RETURN
plo:  lock2 = IN13
      RETURN
atten1: IF attn1 = attn1p THEN atten11
      attn = attn1*2
      '   DEBUG DEC attn, " "
      OUT5=0
      FOR bb = 1 TO 6           'loop for 6 bits
      OUT7=attn.BIT5           ' msb
      PAUSE 1
      PULSOUT 6,100           'pulse clock line
      PAUSE 1
      attn=attn*2             'left shift one bit
      NEXT
      OUT5=1

```

```

    PAUSE 1
    OUT5=0
'   PAUSE 1000
    attn1p = attn1
atten11: RETURN
atten2: IF attn2 = attn2p THEN atten22
    attn = attn2*2
    OUT14=0
    FOR bb = 1 TO 6           'loop for 6 bits
    OUT7=attn.BIT5
    PAUSE 1
'   DEBUG BIT7               'msb of b0
    PULSOUT 6,100
    PAUSE 1                   'pulse clock line
    attn=attn*2               'left shift one bit
    NEXT
    OUT14=1
    PAUSE 1
    OUT14=0
'   PAUSE 1000
    attn2p = attn2
atten22: RETURN

```

Figure 5 Stamp code listing